

INSTALLATION AND SETUP MANUAL

TCX624 Time Corrected Electronic Crossover

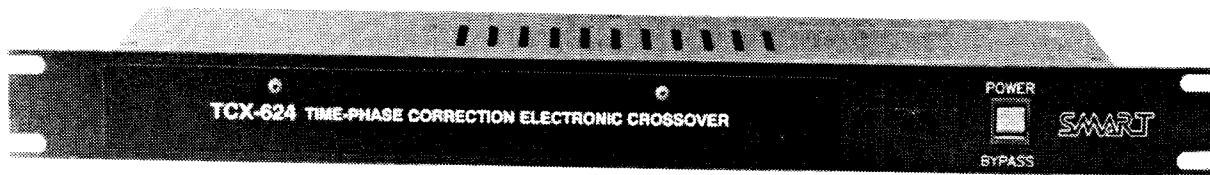

Removable security cover keeps unauthorized personnel from tampering with the settings.

The TCX 624 (Time Corrected X-over) is a multi-channel electronic crossover designed specifically for cinema use. This product contains features not found in other products of its type.

The TCX624 contains three identical crossover channels for the stage speakers, along with its own AC power supply that can operate from 110-120 VAC or 220-240VAC 50/60 Hz line voltages. Each channel has its own adjustment for time correction of the high frequency/horn driver to align acoustically with the low frequency woofer(s). Although it is desirable to use identical stage speakers for stereo in an auditorium, non-similar types can be accommodated and the time correction for each channel can be individually adjusted.

The new constant directivity horns offered by most major loudspeaker manufacturers hold their hold their published dispersion patterns very nicely. Early

New CD horns can hold their pattern throughout the high audio frequency range. Because the pattern is so wide, the higher frequencies are spread over a bigger field and appear not to be as loud as their lower counterparts. The TCX624 has CD horn compensation built in. The smooth high frequency boost is up 12 dB at 10 kHz from the crossover frequency of 500 Hz. The crossover chart below (figure 1) shows the high frequency boost levels off at 10 kHz. This high frequency boost is valuable for movie theatres because of screen attenuation losses at high frequencies. Equalization is easier and smoother with the CD horn correction added.

The crossover frequency of each channel of the TCX624 is 500 Hz. This is the optimum frequency for 2-way stage loudspeakers and agrees with the Academy of Motion Picture Arts and Sciences Technical Standards Commission recommendations. The crossover slope is 24 dB per octave (4 pole filter) to

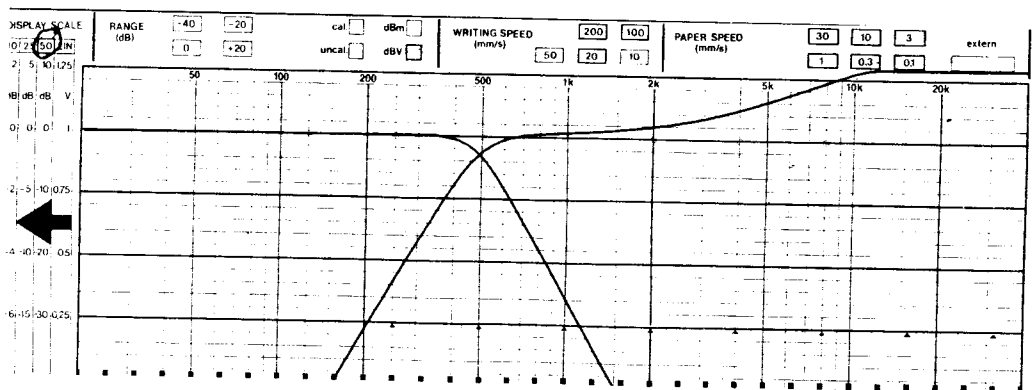

Figure 1. Crossover point and slope of filters. Also CD horn lift curve.

design horns used in cinemas until the early 1960's very very beamy. A horn may have a 90 degree by 40 degree pattern at the crossover frequency, but as the frequency tone went up, the pattern could narrow as low as 10 degrees. You could only hear all tones directly on-axis of the horn.

provide a smooth blend of sounds from the low and high frequency components. The steep 24 dB slope also provides maximum protection for the high frequency driver during loud sound passages.

What is Time Correction?

When a 2-way speaker reproduces a note at (or near) the crossover frequency, both the HF and LF speakers are working at that frequency. Because the HF driver cannot be physically aligned with the LF woofer, the HF sound arrives at the listener's ears slightly behind the sound created by the LF woofer. This creates a muddy, confused sound as frequencies in the range where both speakers operate fight each other causing cancellation and addition of the reproduced notes. If the HF driver is electrically delayed the precise amount of time it takes a note

minimum run of cable.

Wire the outputs to the respective inputs of each power amplifier making sure the LF outputs arrive at the LF amplifier inputs. Reversing the LF and HF signals can cause damage to the HF drivers.

Wire each stereo processor channel to its respective input at the TCX624. All connections are made to the "Entrelec" connector on the back of the chassis. Keep all wiring from this connector away from AC lines and speaker output lines from the power

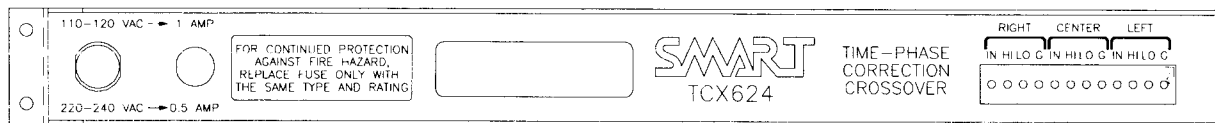

to travel to the listener as the LF note, the two sounds combine acoustically in phase and produce a clear, transparent sound throughout the crossover region. Jumpers have been provided in the circuitry of the TCX624 to align most of the common stage speakers by varying the delay. *Figure 2* shows the mechanical mis-alignment of the HF and LF components in a common stage loudspeaker system.

INSTALLATION

Mount the TCX624 in the equipment rack where it is in proximity to the power amplifiers. An ideal location is where the TCX624 output leads can easily reach the inputs of the power amplifiers with a

amplifiers.

The TCX624 has unbalanced outputs. Wire the inputs of the power amplifiers for this mode.

Allow ventilation space for the electronic crossover. It is not good practice to wedge the crossover between two power amplifiers without vent panels separating the units.

CALIBRATION

Remove the front security cover with the allen wrench provided with the product.

Make sure the power switch is in the ON position. The OFF position is also the bypass mode that allows the audio signals from each channel to pass to the amplifiers. A special protection circuit is included in the bypass circuits to protect the HF drivers from damage from low frequency energy. The LF woofers will receive full range audio when the TCX624 is in the bypass mode. This is not a problem because the woofers will not reproduce HF audio very well.

With pink noise playing adjust the HF level control for the smoothest crossover while observing the response on a real time analyzer set up to monitor the auditorium. The levels should be set to match at the crossover frequency of 500 Hz. Do not be concerned with the level of the other parts of the audio spectrum at this time.

With a ruler, measure the distance from the point

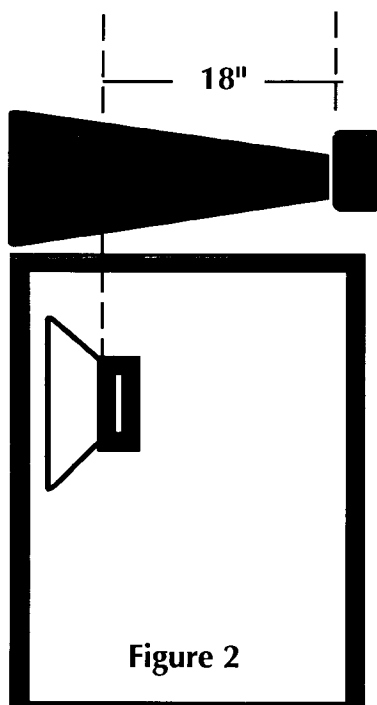
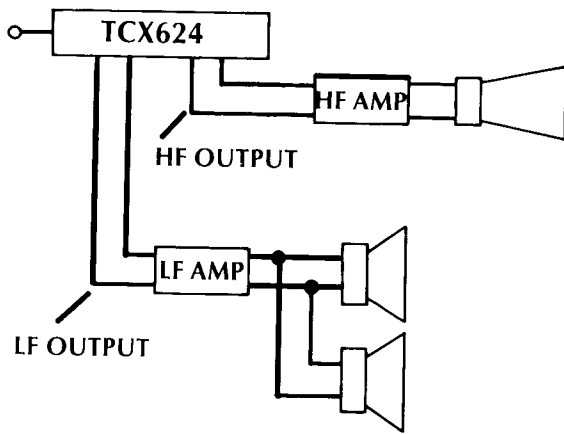

Figure 2



Bi-Amplified System

where the voice coil of the woofer is to the voice coil/diaphragm of the HF driver is located. This is the time offset between the two components. Refer to the chart in figure 3 to determine the best setting of the jumper "shunts" for each channel of the TCX624. You may wish to reposition the mechanical alignment of the horn/HF driver before securing it to the enclosure for an even multiple of 6 inches. For example, if the horn/HF driver is 10 inches behind the LF woofer voice coil, slide the HF assembly back 2 inches so it is an even 12 inches difference. Secure the horn/HF driver assembly to the LF enclosure.

Some manufacturers of cinema loudspeaker stage systems recommend reversing the HF driver connections when using a 24 dB 4 pole filter crossover. Observe your real time analyzer response to determine the best wiring scheme.

POSITION NUMBER	DELAY BY DEGREES	ACOUSTIC DISTANCE
1	180	1 FT
2	270	18"
3	360	2 FT
4	450	2.5 FT
5	540	3 FT

Figure 3

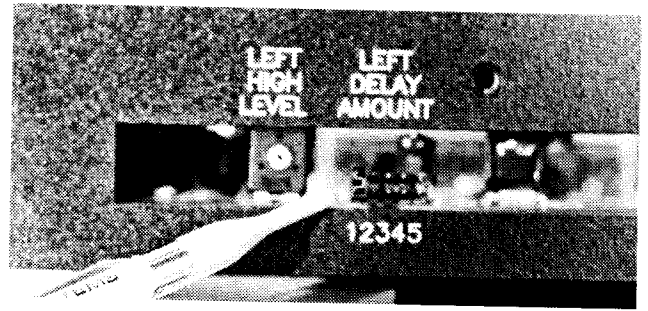

Jumper must be installed on "some" position, or there will be no bass output signal. All channels should be set to the same time correction setting when using identical model speakers.

Leave the security cover off the TCX624 until you have completed your room equalization. This will allow you to make minor adjustments to the HF level setting as you continue to tune for the flattest response.



The premium Entrellec connector makes wiring and replacement easy.

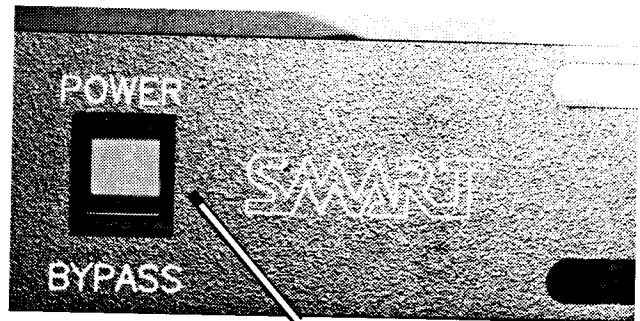

Be sure to instruct the operator to use the bypass button if there is a problem with the TCX624

SMART

5945 Peachtree Corners East
 Norcross, Georgia 30071
 (404) 449-6698 or (404) 45-SMART

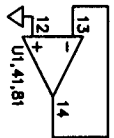
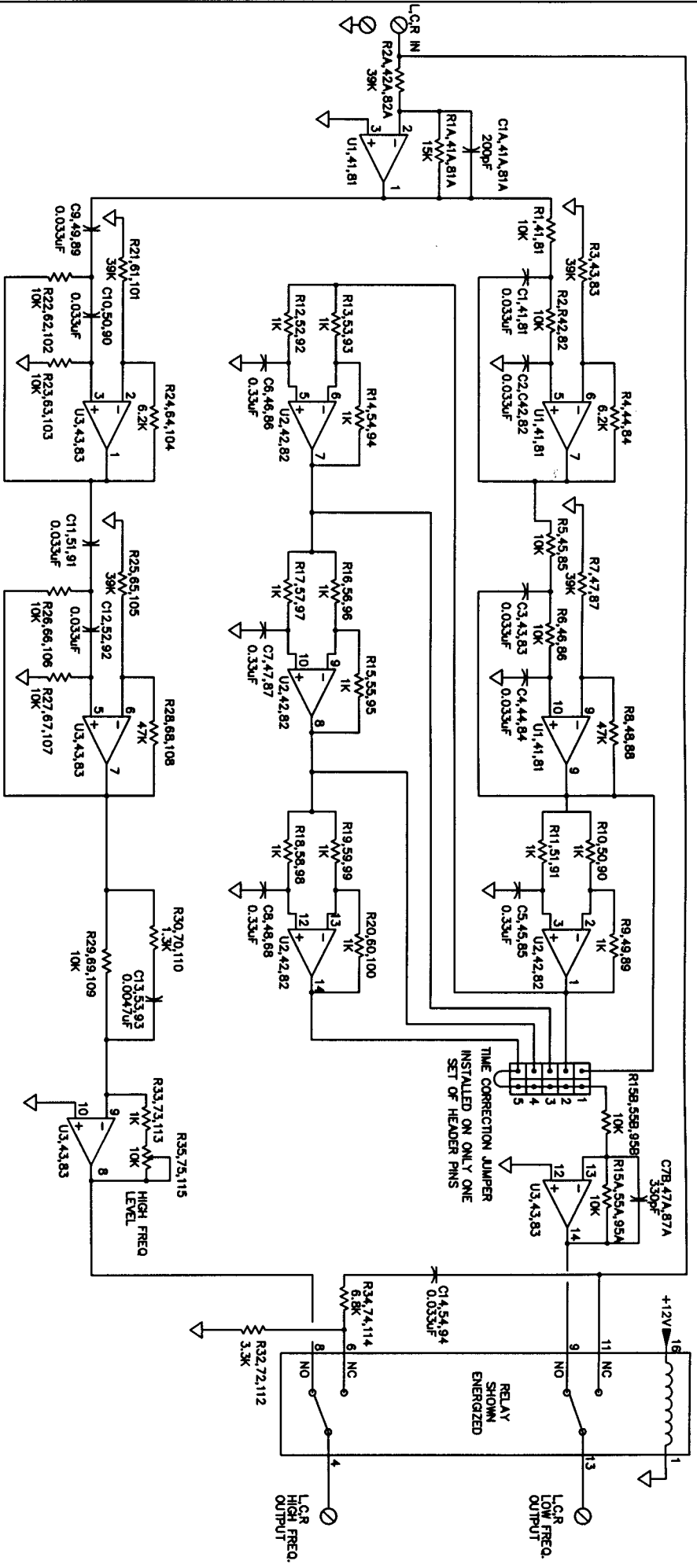

Parts are numbered Left, Center, Right.
 For example, R1,41,81 means this:
 R1 is Left channel
 R41 is Center channel
 R81 is Right channel

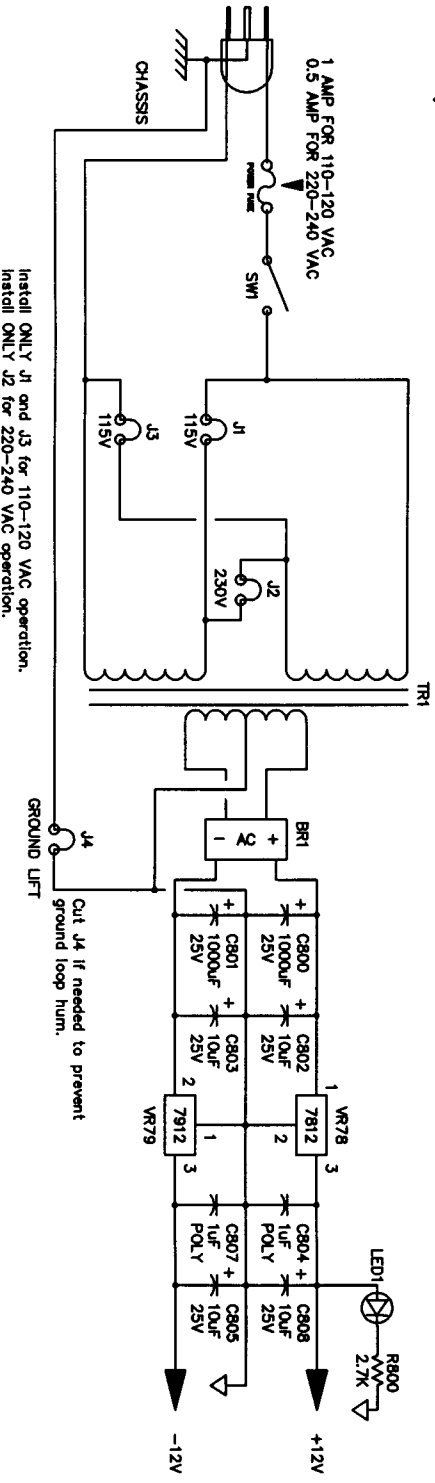

1 AMP FOR 110-120 VAC
 0.5 AMP FOR 220-240 VAC

Install ONLY J1 and J3 for 110-120 VAC operation.
 Install ONLY J2 for 220-240 VAC operation.

Cut J4 if needed to prevent ground loop hum.

SMART THEATRE SYSTEMS			
SCALE	DATE	APPROVED	DRAWN BY:
N/A	05/18/2001		OLN
TITLE			
TCX624 CROSSOVER			
COMMENTS			
DRAWING#			
06240500			