

INSTALLATION AND OPERATION MANUAL

TA380 SUB-BASS THEATRE AMPLIFIER



P.O. BOX 80361

3856 GREEN INDUSTRIAL WAY

ATLANTA, GA 30341

☎(404)-452-1820

TA380 SUB-BASS THEATRE AMPLIFIER INSTALLATION

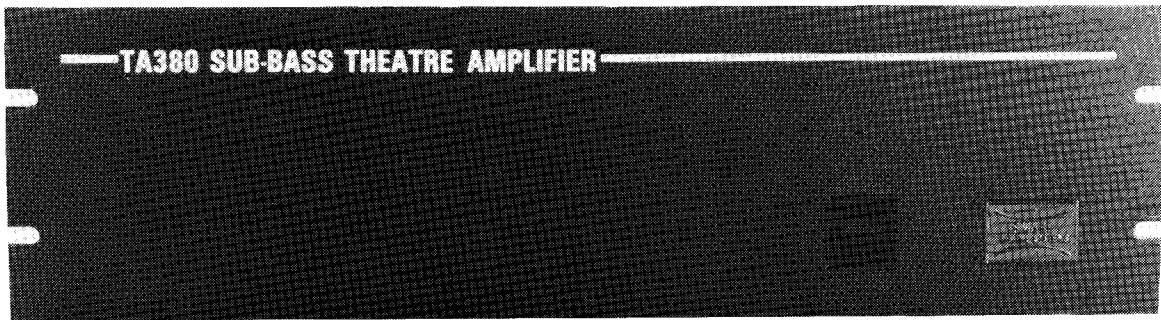

The Front Panel of the TA380 has only a power switch for the operator, with no other operating controls. All settings are made by the installer from the rear of the chassis.

INTRODUCTION

The SMART TA380 Sub-Bass theatre amplifiers combine the latest MOSFET technology with uniquely simple and effective circuitry to reduce distortion of all types, at all power levels, to the vanishing point. The conservative mode of operation accomplishes a new high in long term reliability and exceptional resistance to abusive operating conditions. The MOSFET design overcomes the serious limitations of conventional transistors - their tendency to self destruct under other than normal operating conditions. The TA series of amplifiers is so rugged it can deliver more than ten amperes into a short circuit.

The speed - measured as slew rate - of this design delivers unmatched transient linearity, revealing the most subtle sound shadings, textures, and nuances of the soundtrack material, surpassing the capabilities of most theatre loudspeakers by a wide margin.

The giant toroid power transformer and oversized bridge rectifier; the massive heatsinks; the conservative operating levels of the MOSFET devices - all are evidence of the design efforts to achieve exceptional reliability and state of the art sonic reproduction.

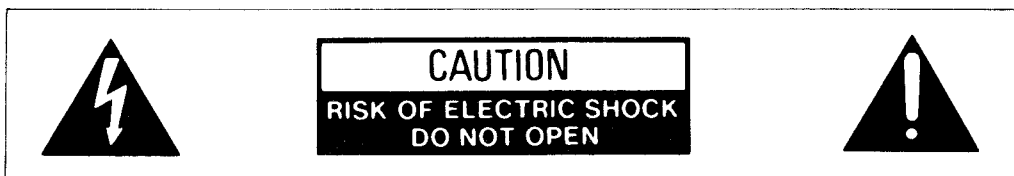

INSTALLATION

The TA380 Sub-Bass amplifier needs 7 amperes of AC power. Make sure that any power switching panel that may be used to control the AC power of the equipment rack can handle the TOTAL AC REQUIREMENTS of the amplifiers. *If a switching panel cannot handle the AC current draw, then do not plug the amplifiers into the panel - but connect the AC line cords from each amplifier directly to the AC line and use the individual front panel power switches on each amplifier to turn the devices on and off.*

If the amplifier(s) are installed close to a high gain magnetic preamplifier, or stereo SVA processor, you should *check its position for freedom of hum pickup* from the field radiated by the power transformer. Although a toroid transformer minimizes such radiation, and the TA series amplifiers are in steel chassis, certain processors are more sensitive than others, and require separation from the amplifier. Often a few inches additional separation will eliminate the problem.

Be sure to provide sufficient ventilation for the amplifier. Unobstructed air circulation around the finned heat sinks and above the amplifier (near the vented top cover) is important for long, trouble-free life. *Never put anything on top of the vent cover perforations.* It is normal for the heat sinks and top to become warm when the amplifier is in use.

AC REQUIREMENTS. The AC power cord should be plugged into 120 volts, 50/60 Hz that can provide at least 7 amperes, or 840 watts. If a switching panel is used in the system to turn all equipment on and off at the same time, be sure the panel can handle the collective current requirements of the equipment. If your line (mains) voltage is different, be sure you have a suitable line-voltage correcting autotransformer or regulating line supply. The performance specifications of the TA series amplifiers are claimed at 120 volts AC.

Special 240 volt AC versions of the amplifiers are available for foreign country applications. Please contact the factory for details on pricing and delivery.

INPUT. Conventional shielded audio cable should be used to connect the output of the processor or preamplifier to the input of the TA series theatre amplifiers. The input to each channel of the amplifier is unbalanced, with one input terminal grounded. Follow conventional professional wiring practice by *grounding the shield ONLY at the sending end of the cable.* Use two conductor shielded audio cable. One conductor of the twisted inner pair is joined to the shield and connected to the grounded output terminal at the processor. The other conductor is the "hot" audio lead, and connects the unbalanced output of the processor to the unbalanced input of the amplifier. *The shield is NOT connected to the amplifier input ground terminal - only the ground conductor of the twisted audio cable.* This procedure will aid in reducing ground loops in the system that can cause hum and the possibility of AC radiated equipment and switching noises.

Most booth processing equipment or preamplifiers have a low impedance output of 600 ohms or less. Cable lengths of up to 50 feet are permissible to the input(s) of the amplifier. Special low capacitance cables enable even greater distances between the processor and amplifier. If the amplifier is remote from the processor, you should avoid running the audio input cables parallel to AC lines - these should be crossed at right angles.



Two sets of output terminals are provided for use when using two subwoofer speakers. Do not allow the impedance of the speakers to equal less than 4 ohms.

LEVEL CONTROLS. The TA series amplifiers contain input level controls that allow individual power output settings for each channel of a stereophonic theatre sound system. The controls are located on the rear of the chassis. Clockwise rotation of each control increases the output level.

OUTPUT(S). The loudspeakers connect to the output terminals on the back panel of the amplifier for each channel of the system. Spade lugs may be connected to the speaker wires to provide a secure and positive electrical connection. Always be sure that no strands of wire are unsecured, and that the bared end of the wire is not too long to risk contacting other terminals or the steel chassis. It is highly recommended that you *test the speaker line with an impedance bridge or ohmmeter* to verify that the speaker wires are not shorted to each other, shorted to conduit, or open. Remember that one of the speaker output terminals is connected to ground at the amplifier chassis and will indicate continuity to other ground points in the equipment rack when measured.

It is important to maintain correct phasing of speakers in a multi-channel sound system. If a speaker phase is reversed in one or more channels, you will find poor stereophonic imaging and bass cancellation between stage speakers. Although surround speakers must be phased to each other, they do not need to be phased to the stage speakers due to the great physical distance in placement in the auditorium. Also, the surround channel of most stereo SVA decoders has a time delay to mask crosstalk. The electronic delay introduces an even greater time difference in the total system.

TA380 BASS AMP

Select speaker wire of sufficient size to preserve the high damping factor of the amplifiers - and minimize power loss to the speakers. If the speaker load is 4 ohms (surround speakers), be sure to double the gauge of wire for the lower impedance.

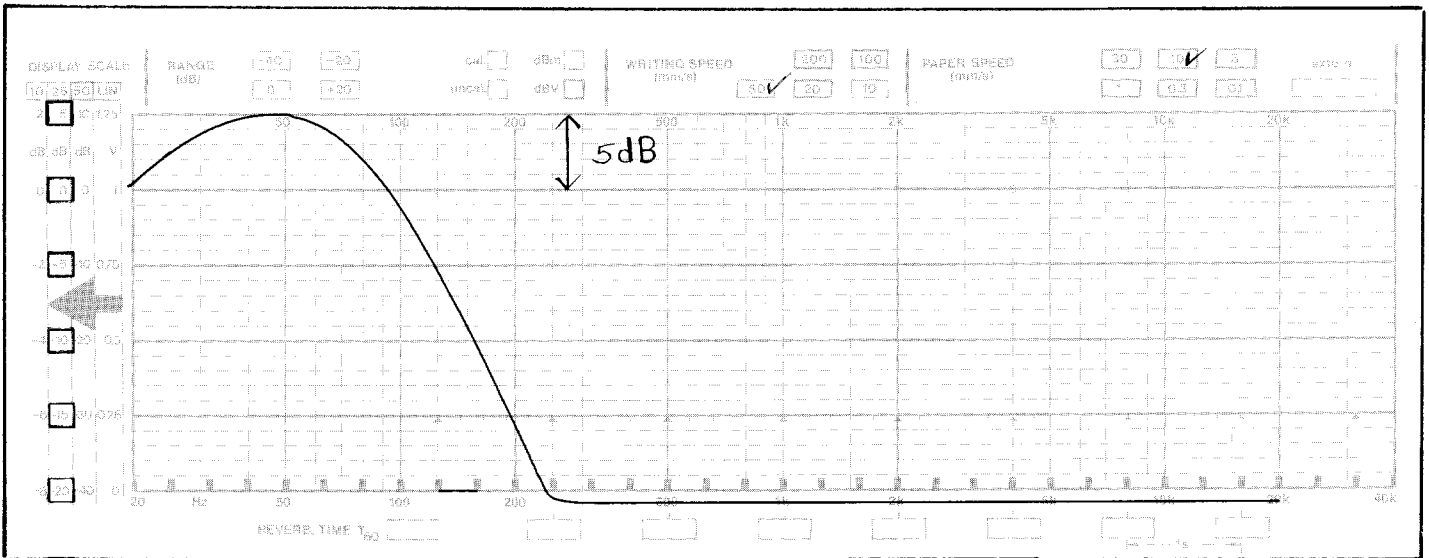

The band-pass response curve of the TA380 allows only the deep bass to be sent to the speakers. Notice the Low-Pass and High-Pass filter response.

WARNING!

The power cord is terminated in a “U-Ground” plug to USA standards. The green/yellow wire, connected to the long prong, is electrically attached directly to the chassis. Some sound engineers will lift this ground to suppress ground loops with a three prong to two prong adapter plug, rather than damaging the power plug. It is not recommended that the ground be defeated because it eliminates the intrinsic safety feature of the three-wire system.

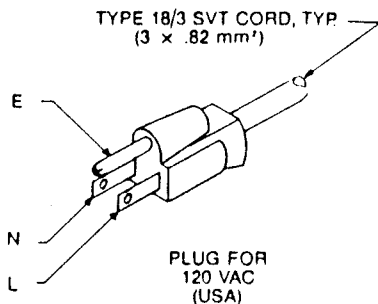

CONDUCTOR	WIRE COLOR	
	Normal	All
L LINE	BROWN	BLACK
N NEUTRAL	BLUE	WHITE
E EARTH GND	GREEN-YELLOW	GREEN

AC MAINS LINE CORD DETAIL

Helpful Hints

1. Do not run input and output signal leads side by side. Dress the output leads to the Left of the equipment rack (when viewed from the rear) along with the AC line, and input leads along the Right side of the rack.
2. Keep spare fuses on hand for emergencies. See that the operator has a supply OF THE PROPER VALUE.
3. Leave a manual for this equipment with the Operator or Manager so that other service people can efficiently service this equipment.

SERVICE

IMPORTANT



The lightning flash with arrowhead, within an equilateral triangle, is intended to alert the user of the presence of uninsulated "dangerous voltage" within the product's enclosure that may be of sufficient magnitude to constitute a risk of electric shock to persons.

CAUTION

**RISK OF ELECTRIC SHOCK
DO NOT OPEN**

CAUTION:
TO PREVENT THE RISK OF ELECTRIC SHOCK, DO NOT REMOVE COVER (OR BACK). NO USER-SERVICEABLE PARTS INSIDE. REFER SERVICING TO QUALIFIED SERVICE PERSONNEL.



The exclamation point within an equilateral triangle is intended to alert the user of the presence of important operating and maintenance (servicing) instructions in the literature accompanying the appliance.

WARNING

Disconnect the power supplies from the AC power line before replacing components to avoid the danger of electrical shock.

The SMART TA380 amplifiers have field replaceable modules. Each circuit module contains all the active circuitry for each amplifier channel. It is generally not necessary to replace an entire amplifier unit because of the modular design and construction of the TA series. See the section of this manual that refers to module replacement.

If a certain problem lies in the power amplifier, check the output signal of the amplifier. If a channel cycles on and off during normal operation, excessive temperature on the heat sinks has shut the amplifier down. After a few minutes of cooling, *the channel will re-activate automatically*. If it soon shuts down again, and there is sufficient ventilation and properly loaded, the malfunction is either internal, or the result of an excessive (and very likely inaudible) input signal. In that case, the cause must be investigated.

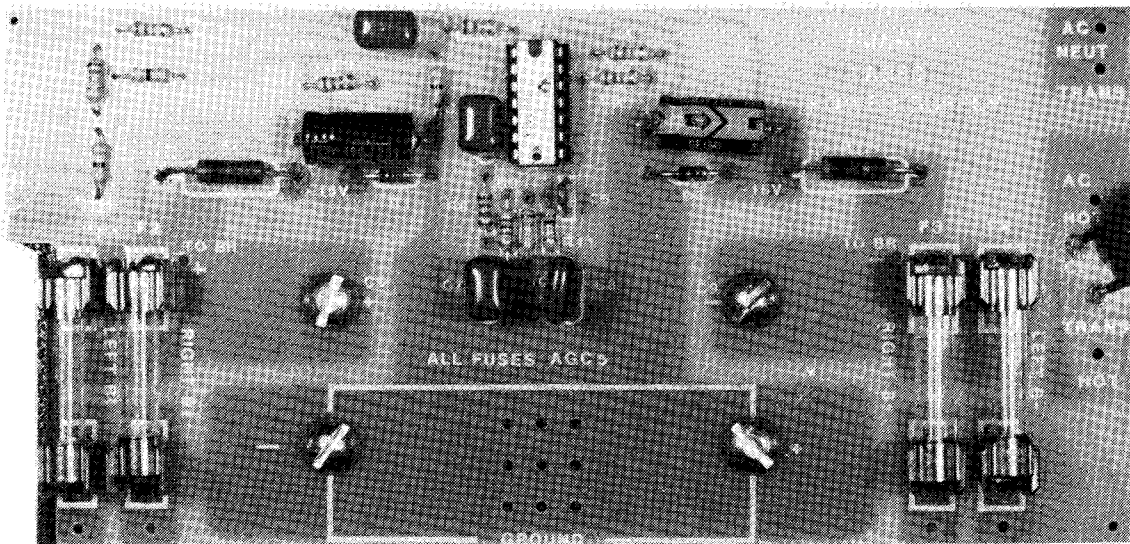

View of the power supply and active filter section. The DC power rails fuses are on this card.

If the front panel power light is not illuminated, the main fuse on the rear panel of the chassis is probably open. If the fuse replacement does not correct the symptom, the amplifier has a power supply problem, and requires professional service.

A problem with only one channel (in the dual channel TA380) may be isolated by removing one set of B + fuses in the amplifier chassis, and the other channel may still be left in service. A faulty active amplifier module may be returned to the factory for service or replacement. Shipping a module only reduces shipping weight and the likelihood of damage.

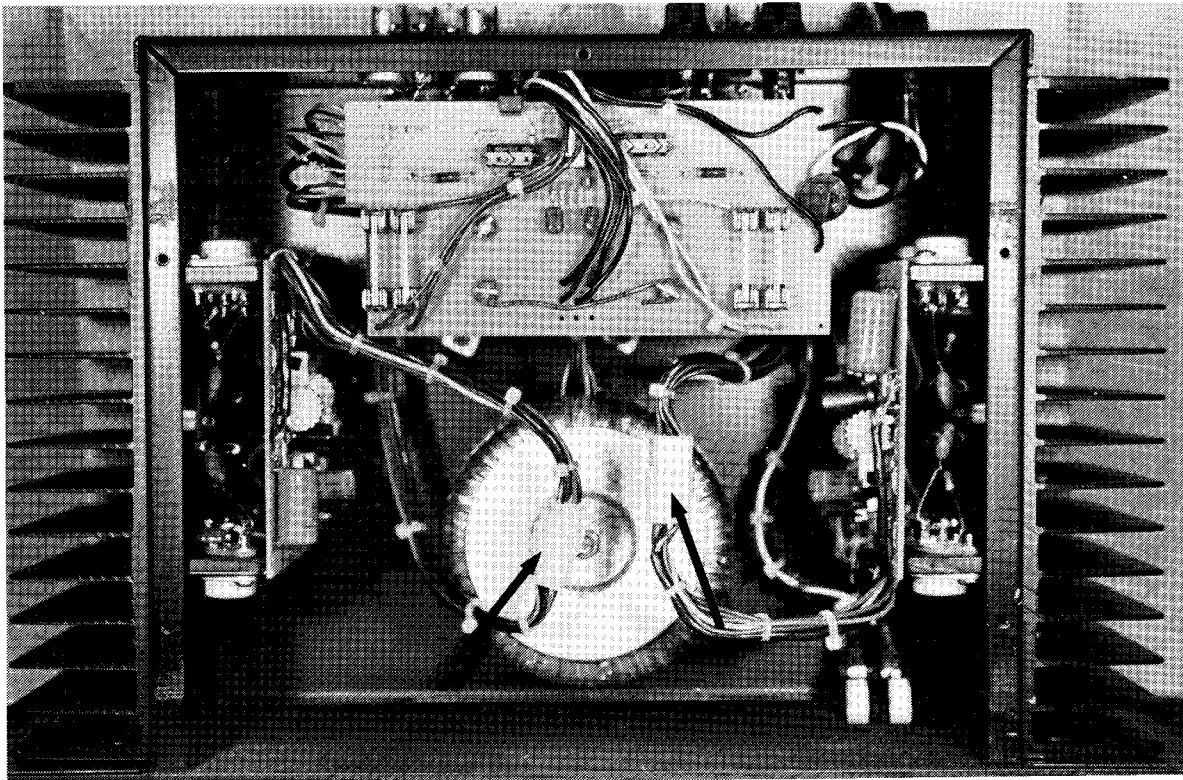

Arrows point to the Molex connectors which allow the modules to be field replaced. The top cover does not need to be removed.

To remove a module, locate the four (4) 6-32 machine screws that secure the module to the steel chassis. They are located inside the heat sink fins near the ends of the module. Remove (and save) the screws. Pull the module straight out to the length of the connecting cable. Separate the Molex connector, and place a plastic bag and rubber band over the portion of the Molex connector that is in the chassis. This will allow you to operate the amplifier's surviving channel (in the dual channel model) without risk of shorting a cable to the power supply parts. We also recommend that the two B + fuses are removed from the channel that was de-activated. When the replacement module is installed, the fuses must be replaced.

CAUTION

Service instructions are included for use by qualified personnel only. To avoid electrical shock, do not perform servicing other than that described within the Operating Instructions unless you are qualified to do so. Refer all such servicing to qualified service personnel.

Repairs to this product should be performed in accordance with applicable safety standards, and should be performed only by a trained service technician.

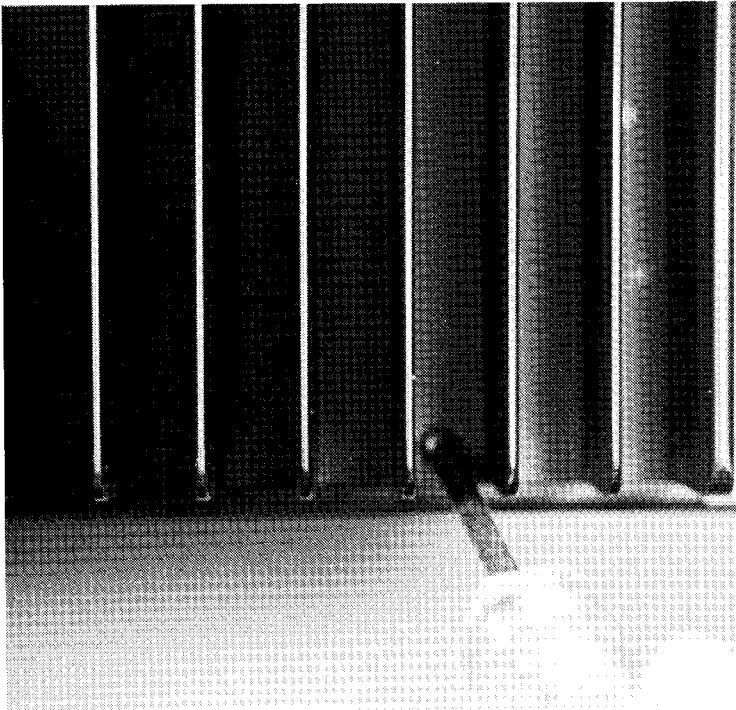

Four Phillips screws hold each amplifier module to the chassis. Use a long blade screwdriver to remove the screws. Extra length has been provided on the connecting cables to make replacement easy. The top cover of the chassis need not be removed to replace modules.

If the ground is defeated, certain fault conditions in the unit or system to which it is connected can result in the appearance of full line voltage between the chassis and earth ground. Such voltage is capable of causing electrical shock, possibly resulting in severe injury or even death!.

It is the theatre or serviceman's responsibility to ship the faulty components *prepaid* to the factory service department. Units shipped freight collect will not be accepted. Units that are repaired while in warranty will be returned prepaid to the owner. Factory date marks that have been deleted or altered will not be considered under warranty. Warranties are void if: A) The amplifier has been physically or electrically abused or used for some purpose for which it was not designed, or B) The amplifier has been modified without factory authorization.

SERVICING AN AMPLIFIER MODULE. If you are certain that the problem is confined to one of the amplifier modules (comprising the circuit board, heat sink, and output MOSFETs), you may elect to return the module **ONLY** for factory repair. *Be sure the components on the circuit board are well protected* - by surrounding the component board with corrugated cardboard which projects beyond the components. If you have the proper replacement components and know-how, you may wish to repair the module. Be sure to replace components with the exact replacement value.

ADJUSTMENTS FOR BIAS AND DC OFFSET. The two bias potentiometers on each circuit board have been set by the factory and should not require adjustment for the life of the amplifier. In the event of repairs such as transistor replacement, the following procedure should be followed after removing the input and output connections to the amplifier.

BIAS. Turn the amplifier off. Remove the B + fuse. This fuse is in line from the bi-polar power supply positive filter capacitor. Connect an ammeter's plus test lead to the fuse clip that comes from the capacitor. Connect the other ammeter test lead to the other side of the fuse clip. Avoid intermittent connections, and do not short the test leads together. Turn the amplifier on , and if possible, adjust the AC line voltage to 120 volts. Adjust P2, near the middle of the circuit board to 275 mA. Turn the amplifier off, and when the current drops to zero, then remove the ammeter and replace the fuse.

OFFSET. A DC voltmeter capable of resolving 10 mV variations is needed. Connect the meter to the output terminals of the selected channel, and adjust P1, near the top of the board, to zero volts. A small correction of the control will produce a large initial change, which will settle down in a few seconds. Repeat these small changes to achieve zero volts.

POWER SUPPLY. The power supplies in the TA380 Theatre amplifiers are very reliable and rarely fail. The large toroid transformer, and 25 ampere diode bridge are heavy duty components and are selected for long life and trouble free operation. Check the output of the large filter capacitors with a voltmeter before replacing parts. Un-plugging the active amplifier modules or removing the B + and B- fuses to each channel will allow you to examine the power supply separately. Turn the AC power off before connecting your service meter probes. Each of the large filter capacitors is referenced to ground. With you test lead connected to the positive terminal of the positive filter capacitor, a DC reading of 65 volts should be observed. Connecting your negative lead of the meter to the negative filter capacitor terminal should reveal -65 volts when the amplifier is not be driven with audio. These measurements will vary if the AC line voltage is not 120 VAC.

DISTORTION. If any of the internal power supply fuses blow out, *distortion will be heard* in the audio output of the affected amplifier channel. The fuses are mounted inside the chassis, and can be replaced by removing the rack panel mounting screws, sliding the amplifier forward, and removing the protective chassis top cover. *This procedure should be performed only by qualified service personnel.* Check to see that there is no damage to any of the components before replacing the fuses. If the fuses blow again, you may have a faulty component.

SMART THEATRE SYSTEMS reserves the right to improve or update models without prior notice. Changes may not be reflected in the current sales or technical literature. The **SMART Technical Support Department** may be helpful in answering field technical problems of installation and service. Engineers are available during normal business hours (Eastern Time) at **(404)-452-1820** or **(800) 45-SMART**

OPERATION

The amber pilot light which is integrated into the AC power switch on the front panel glows whenever the amplifier is turned on. The pilot light is neon and has an extremely long service life. A blown AC line fuse is the most likely cause of the pilot light to not be illuminated when the amplifier is turned on.

If the amplifier cycles on and off during normal operation check for a shorted, or abnormally low speaker impedance. The thermal circuit breaker *will reset automatically* when the load has been removed or corrected and the heat sink has returned to a normal temperature. Also, check for insufficient ventilation, an excessive input signal, or an input which may have dangerous signal content (such as oscillation). Because of the large heat sinks, it is unlikely that any normal signal will cause the amplifier to overheat.

A pair of 5 amp fast blow fuses are supplied in the speaker fuse holder(s). These fuses (along with the main AC fuse) are replaceable from the rear of the chassis. If the amplifier is to be operated at very high level into a low impedance load (4 ohms), *the speaker fuses may have to be increased to 8 amperes.* A typical application is the surround channel speaker string that may consist of many medium efficiency speakers wired in series-parallel. The fuses are used for speaker and amplifier protection and should not be increased above 8 amperes per channel.

CAUTION: IF THE INTERNAL FUSES BLOW, SOME DISTORTED SOUND MAY RESULT. IF THE AMPLIFIER MALFUNCTIONS, ALWAYS CHECK FOR BLOWN FUSES FIRST.

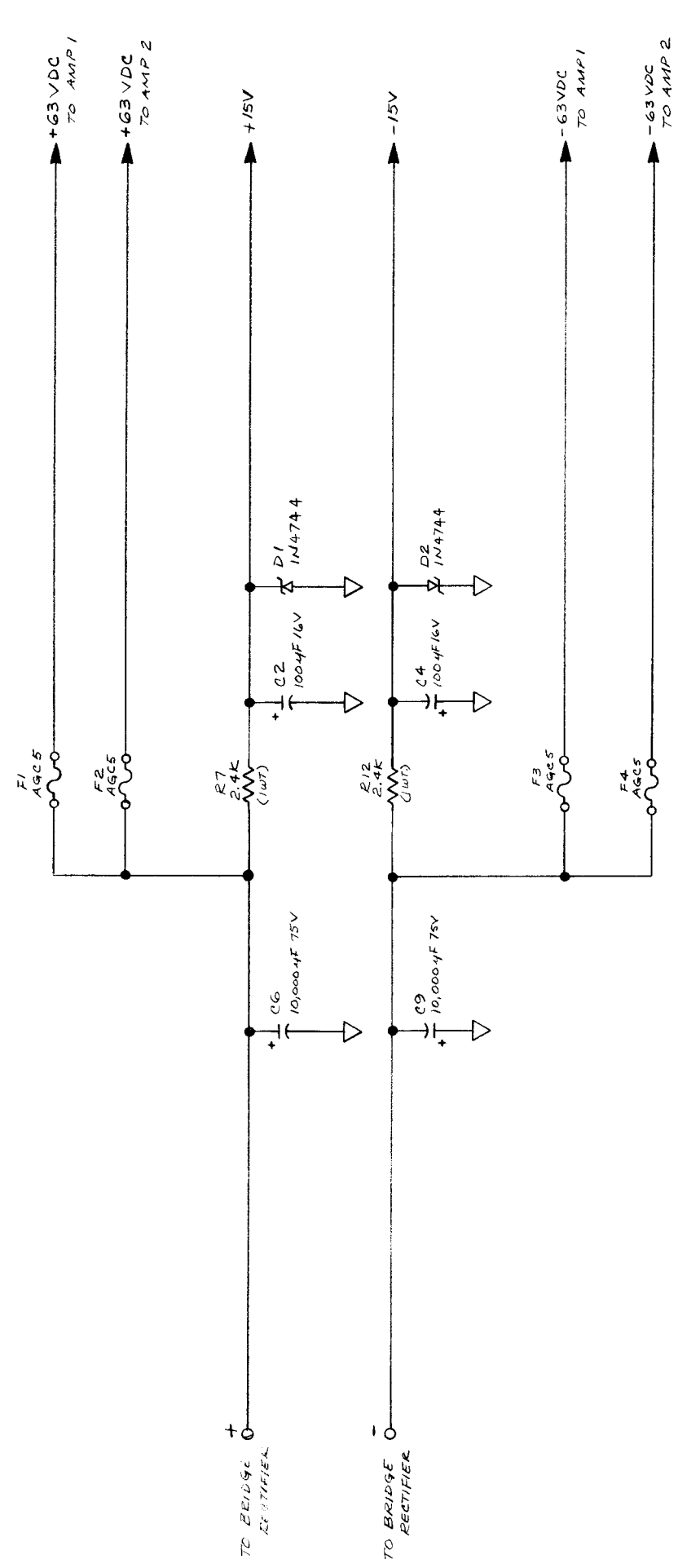
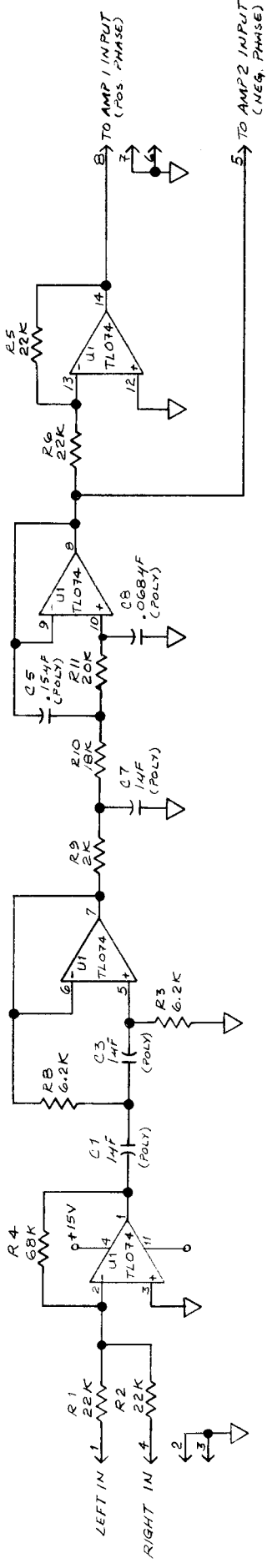

Smart Theater Systems
 SCALE: 1/1
 DATE: 6-25-85
 APPROVED BY: [Signature]
 DRAWN BY: [Signature]
 POWER SUPPLY / CROSSEXCHANGER CARD
 TA380 SUBWOOFER AMP
 DRAWING NUMBER: 03B0R500

TA380 BASS AMP

* TELEPHONE BOOK 184B-15E

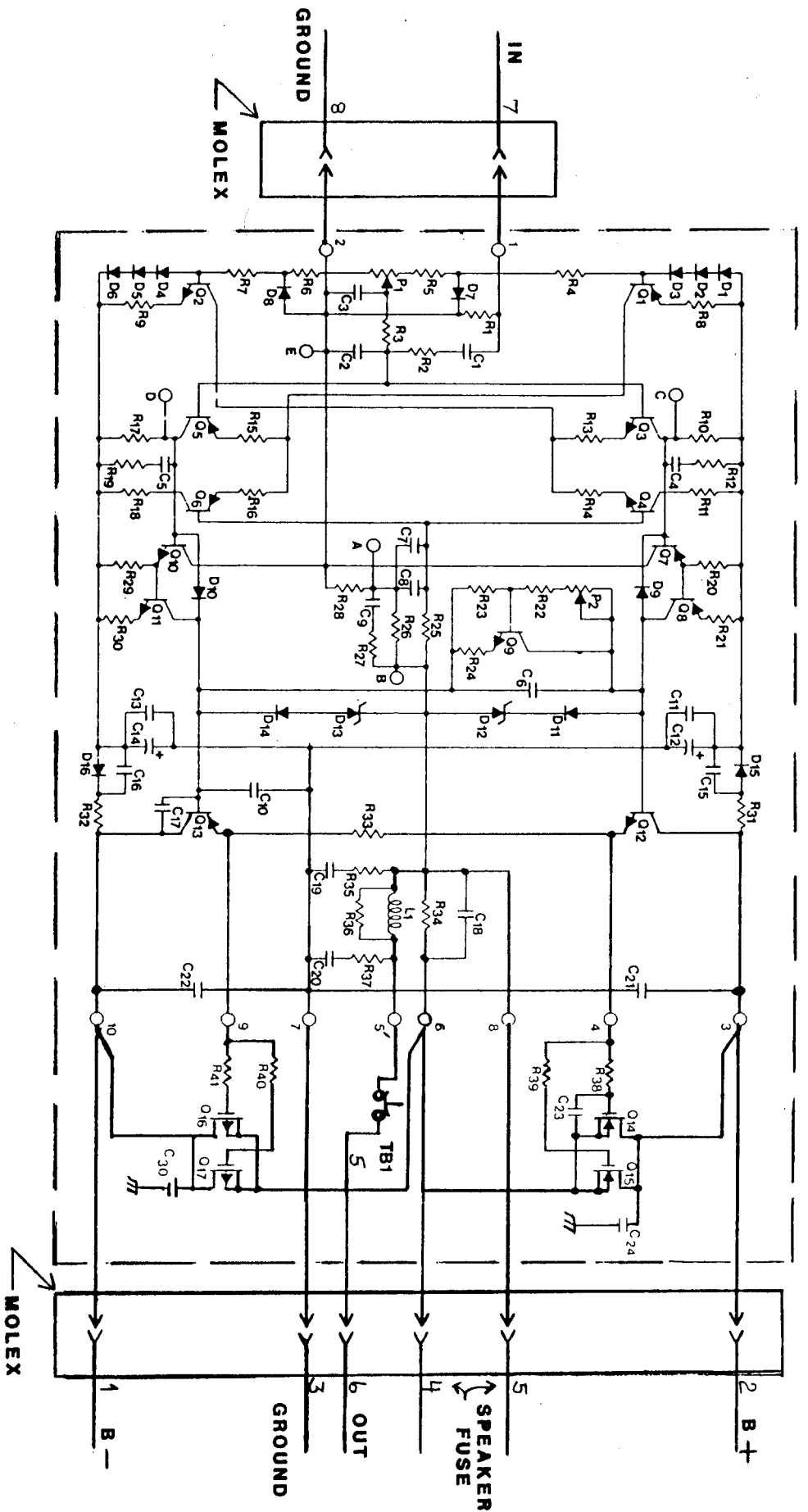

TA380 BASS AMP

NOTES

- 1) TB1 IS THERMAL BREAKER IN SERIES WITH LOAD
- 2) TYPICAL OF BOTH CHANNELS

SMART THEATRE SYSTEMS			
DRAWN BY:	DATE:	SHEET:	
OUJ	8/7/84	2 OF 2	
SCHEMATIC - MODULE			
TA240 & TA242		0242A500	

TA380 BASS AMP

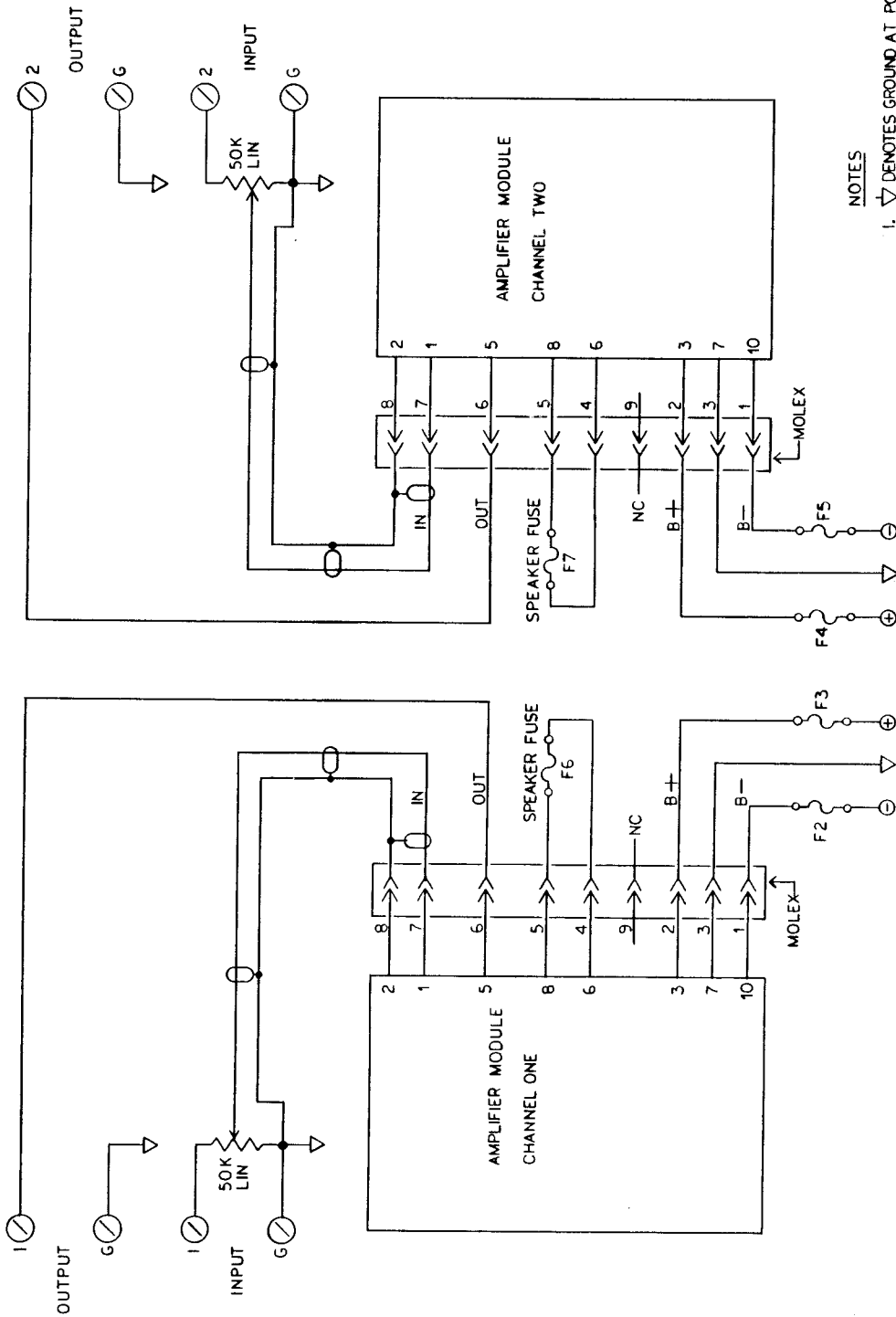

NOTES

1. ▽ DENOTES GROUND AT POWER SUPPLY
2. F1 IS AGC 5 WITH 8Ω LOAD, AGC 8 WITH 4Ω LOAD
3. F2-F7 ARE AGC 8
4. D1 IS 15 AMP 200 V BRIDGE
5. Ⓢ DENOTES SHIELDED CABLE

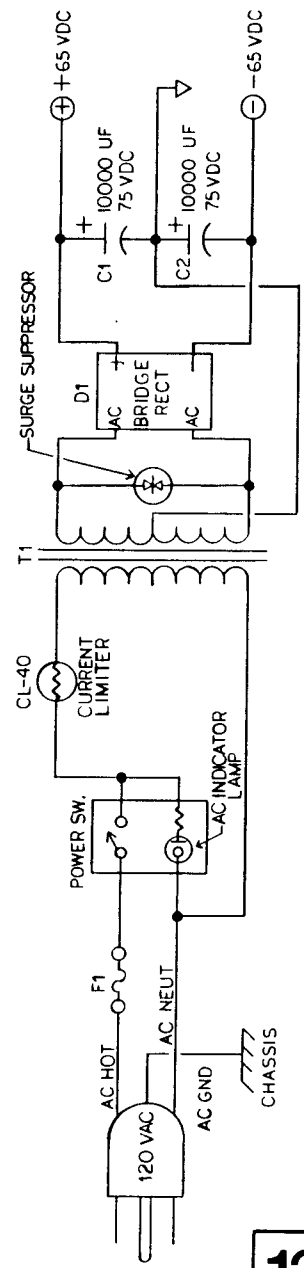

SMART THEATRE SYSTEMS	
DRAWN BY: OLN	REV: _____
DATE: 7-30-86	SHEET: 1 OF 2
TITLE: SCHEMATIC - DUAL CHANNEL AMP	
MODEL: TA240 & TA242	DRAWING # 0242A500

PC 19 MOSFET AMPLIFIER MODULE

PC-19B

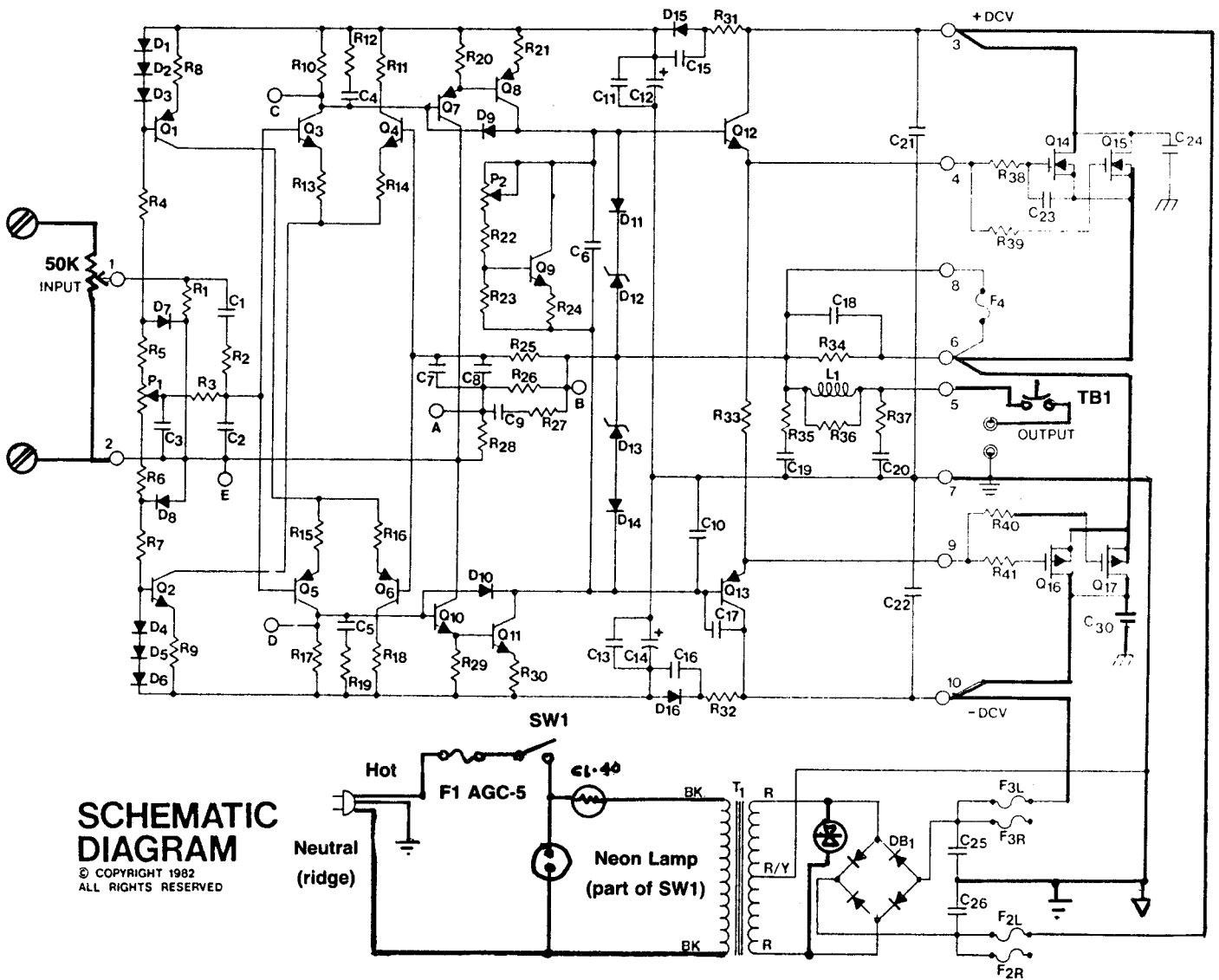

SCHEMATIC DIAGRAM

© COPYRIGHT 1982
ALL RIGHTS RESERVED

Neutral
(ridge)

NOTES:



= CIRCUIT GROUND



= CHASSIS GROUND

MODULES ARE CONNECTED THROUGH 9-PIN MOLEX CONNECTORS



FOR NORMAL 8Ω OPERATION ALL FUSES ON BACK PANEL ARE AGC-5 AND INTERNAL FUSES ARE AGC-4.

FOR 4Ω SPEAKER LOADS F1 MAY BE INCREASED TO 7 AMPS AND F2 & F3 INCREASED TO 8 AMPS.

Amp Module for TA380 Sub-bass Amplifier