



Copyright 1995 by SMART Devices Inc.
5945 Peachtree Corners East
Norcross, GA 30071-1337

Table of Contents

SECTION 1	INTRODUCTION	2
SECTION 2	CARD DESCRIPTION	3
SECTION 3	INSTALLATION.....	7
	- WIRING HOOKUP INSTRUCTIONS	7
SECTION 4	CALIBRATION.....	10
	- B CHAIN CALIBRATION.....	10
	- A CHAIN CALIBRATION.....	12
SECTION 5	OPERATING INSTRUCTIONS.....	13
SECTION 6	SERVICE	13
SECTION 7	SCHEMATICS	16

SMART products are designed to deliver unsurpassed quality in workmanship and performance. The following information gives detailed instructions on the installation and operation of the SMART MOD V processor. We strongly encourage new owners of the MOD V to thoroughly read this entire manual before placing their new SMART product into service. This will ensure that the MOD V will be operated properly to give the superior performance that it was designed to deliver.

For service or installation assistance, please call our
Technical Support Department between the hours of
8 a.m-5 p.m. E.S.T., Mon.-Fri.
1-800-45-SMART

LIMITED WARRANTY: SMART products and accessories are warranted against malfunction or failure due to defects in workmanship or materials for a period of one year from the date of shipment. If a problem occurs during the warranty period, the unit will be repaired, or replaced at our option, without charge for materials or labor. If air freight is requested by the dealer, the difference between air and surface charges will be billed to the dealer. This limited warranty does not cover products that have been abused, altered, modified, or operated in other than specified conditions. Prior factory approval is required on all returns. Returned equipment or defective parts must be shipped freight prepaid to us by the dealer or customer.

Our limited warranty does not cover damages resulting from accident, misuse or abuse, lack of responsible care, or failures not attributable to manufacturing defects, except as provided herein. SMART Devices, Inc. makes no warranties, express or implied, including warranties of merchantability or fitness for a particular purpose.

RETURN POLICY: Factory authorization MUST be obtained before returning any product. A 15% restocking charge will be issued on unused equipment (in original box) that is returned for credit. Credit is issued to the dealers account. The credit may be used against future purchases and no cash transactions are offered. All returns must be shipped freight prepaid by the dealer. Equipment returned without a factory RA (Return Authorization) will be refused.

Installation and Service Manual

MOD V Digital/Optical Stereo Cinema Processor

INTRODUCTION

The MOD V Stereo cinema processor is a full 8 channel system delivering superior audio quality for any theatre. This advanced processor comes standard with many features, yet is easy to operate, making the unit the best buy on the market. The MOD V is fully compatible with all digital formats, and was designed to easily process 70mm and 35mm magnetic soundtracks.

To achieve optimum results from your new MOD V cinema processor, the theatre engineer installing the system should be totally familiar with all features and adjustments. Careful attention to detail and familiarity with the installation instructions will allow you to offer a system that has a sound quality second to none.

FEATURES

In addition to the standard features you find on other processors, the MOD V offers many extras that makes operation easier and more flexible.

FADER CONTROL:

To begin, the MOD V has one MASTER FADER that controls the overall playback level for all 8 channels. This master fader is used as the volume control for all formats except music mode. Seven trim controls on the front panel independently fine tune adjust (± 3 dB) the volume level of each format. The music control on the front panel is the master music level control. The trim faders allow matched levels when the MOD V transitions between various formats. This unique feature allows the MOD V to operate without constant attendance by a projectionist.

STATUS INDICATORS:

The operator control panel features a STATUS DISPLAY readout that shows the mode the system is in at any time. Red LED's show which format is selected. The indicator lights can be seen from a distance so it is not necessary to be near the processor to verify the status. LED arrays on the front panel indicate relative volume level for the five primary channels: Left, Center, Right, Left Surround and Right Surround.

UPDATING FOR THE FUTURE:

Since the MOD V processor is totally modular, any new circuit developments or additional options may be added easily. This can be achieved by simply plugging in a new card into the existing card cage when a factory exchange or update promotion is offered. The system can stay up with current and future technology at minimum expense.

MOD V COMPONENTS:

There are two main components included in the MOD V system: the power supply and the card cage. There are also several optional plug-in cards to give the system more features and greater flexibility. The system cannot operate without the two main components, but can operate without the options.

— POWER SUPPLY:

A heavy duty fully-regulated power supply is furnished with the MOD V processor. This bipolar supply is heavily filtered and supplies ample current for both the positive and negative 20 VDC supplies. This external power supply minimizes the chances of hum pickup when high gain electronic circuits are placed in the same chassis as a power supply. Also, the large power capacity of the supply provides a very "stiff" voltage to all cards in the MOD V to prevent power sag (momentary drop of the supply output due to heavy loads). This gives excellent transient peak response and superior stability.

— CARD CAGE:

The "working" part of the MOD V system is housed in a card cage rack mount assembly that contains plug-in component cards for easy servicing and future expansion of the system. A theatre may elect to start with a basic OPTICAL STEREO sound system, update to a digital stereo system, and eventually an eight channel system with sub-woofer. The SMART MOD V is fully equipped to handle your expansion needs. The MOD V will easily handle magnetic soundtracks with the addition of external magnetic preamps and two more noise reduction cards that easily plug into the main card cage.

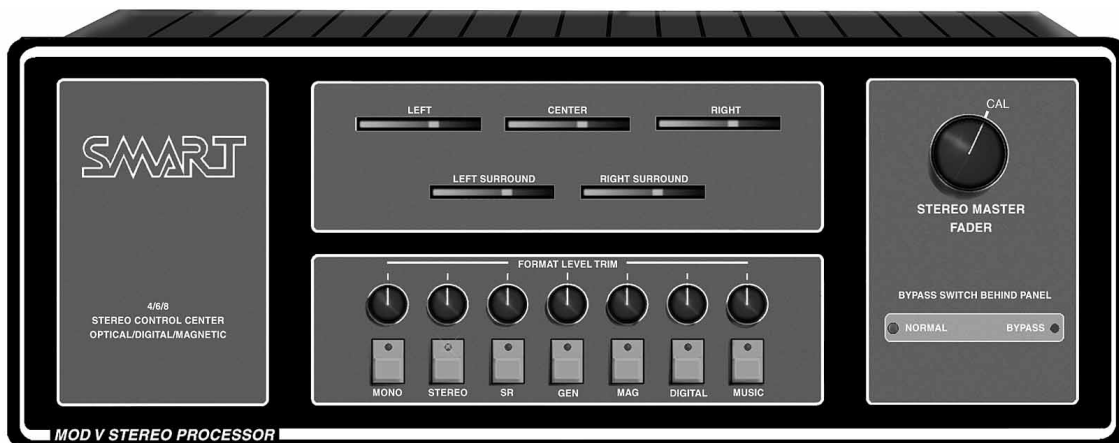

CARD DESCRIPTION

Each circuit card in the MOD V has its own on-board voltage regulators that stabilizes the circuits locally as well as filter unwanted signals that may be present on the main power busses.

Test points are included on some cards for the sound engineer to access vital circuit points with his scope or meter. These terminals will accept a meter probe or "alligator" clip.

FRONT DISPLAY CARD: MOD5X380

The front panel is where the Master Film Fader and individual Format Trim Level controls are located. This important card has three switches (located on the inside of the unit) which are used for selecting various modes. To access these switches, just pull the front panel forward from the top. The hinged front panel allows easy access to these switches.

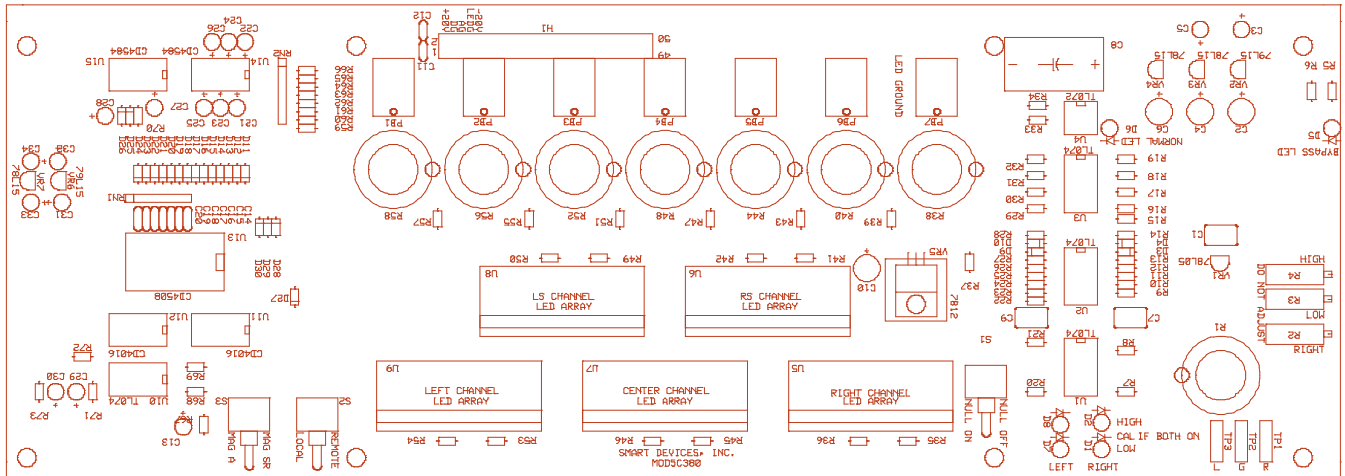

The NULL switch is used during setup to change the LEFT SURROUND LED ARRAY circuit to indicate when a proper surround null has been achieved. It should normally be left in the OFF position. The VOLUME switch selects either local volume control or remote volume control. The third switch (only on the "C" version or later of the circuit board) is the MAGNETIC NR switch which is used to select Type A or Type SR noise reduction for MAG prints. This switch is normally set to MAG A.

Test points 1-3, located on the front right hand side of the board, is where you will find a convenient location for probing the left and right outputs of the preamp card. The four red LED's next to the preamp test points are used for setting preamp levels during setup.

NOISE REDUCTION CARDS: MD2BX374

The SMART noise reduction cards provide noise reduction for decoding Dolby type A stereo prints and Spectral Recording (SR) encoded prints. The noise reduction circuitry is automatically switched to the proper mode when selected by the format switches on the front of the processor. There are four trimpots and two test points on each NR card. **These are for factory use only.** Do not attempt to adjust these trimpots or use the test points. Two of the NR cards (slots 1 and 2) are dual purpose. They are used for both optical stereo and for mag soundtracks, left and right channels. The other two cards (slots 3 and 4) are strictly for mag use only, center and surround channels. These two are optional and are not shipped with every MOD V, since they are only used for sound systems equipped for magnetic prints.

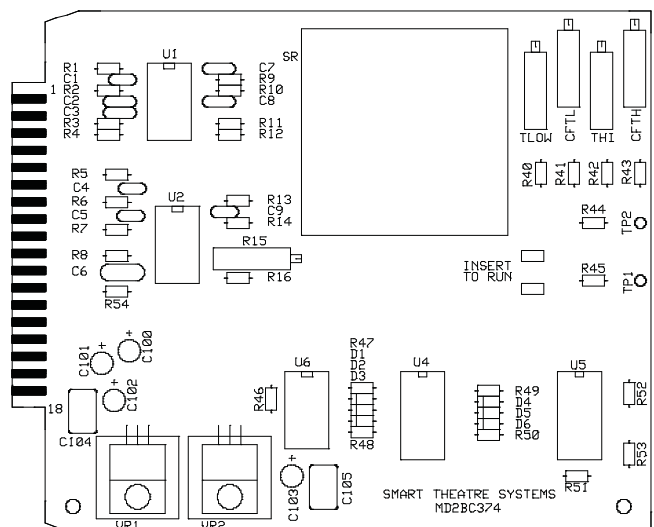

**EXTERNAL INPUT/NR SWITCHING CARD:
MOD5X349**

This card handles several functions related to external magnetic and digital signal sources, NR switching, and magnetic modes. Source selection of digital or magnetic signals is provided by electronic switching I.C.'s. These determine which signals appear on the main signal busses of the MOD V. This is dependent on which format is selected. The Left and Right NR cards are switched between optical and mag sources, again dependent on the selected format.

This card also has 2 toggle switches to select various magnetic sound modes. The bottom switch selects MAG NR ON or OFF. Since most mag prints use NR encoding (Dolby 70), this switch is normally ON (up position). The top switch selects mag mono surrounds or split surrounds. Because most mag prints do not have split surrounds, this switch should normally be left in MONO (down position).

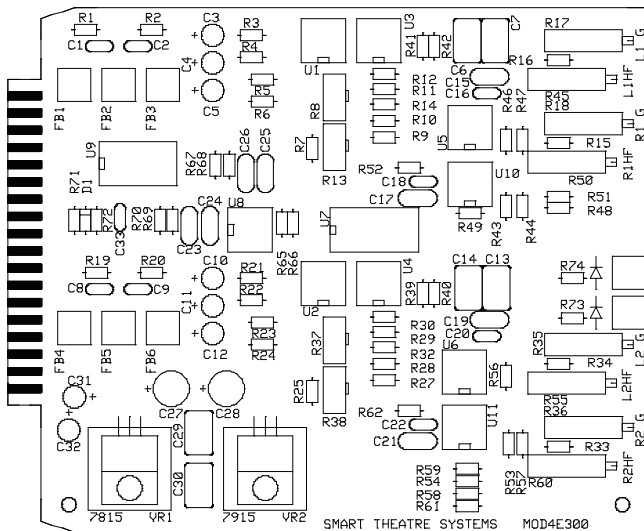
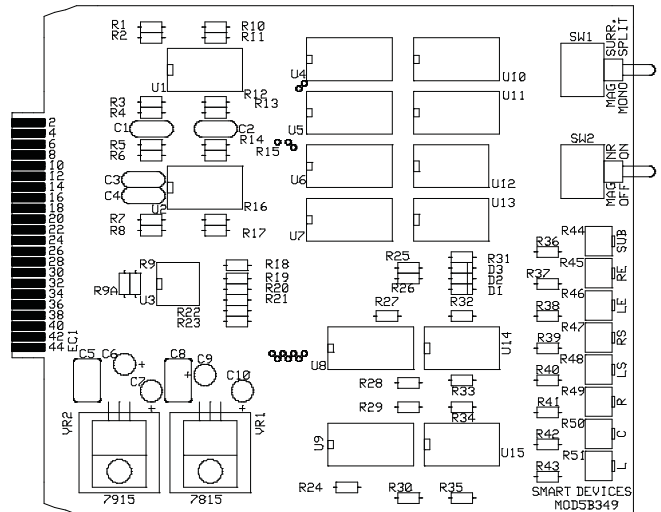

**DUAL PROJECTOR PREAMP CARD:
MOD4X300**

There are 2 stereo solar cell preamplifiers in the MOD V: each preamplifier channel is equipped with slit-loss correction. The Stereo-optical preamplifiers on this card increase the incoming level from the stereo solar cells. Electronic changeover circuitry between stereo pairs is built on the card to allow use in dual projector booths. If the MOD V is installed in a single projector booth, leave the second projector inputs unconnected.

The Dual Projector Preamp Card has two solar cell preamplifier gain controls and two slit-loss correction circuits for each projector. There is sufficient gain built into the preamps for narrow slit optical sound lenses when the exciter lamp is run at 80% of its rated value. The card is silk screened to make it easier to see the location of each preamplifier gain and slit-loss correction control pot.

**MONO/BACKUP CARD:
MOD2X305**

The MONO card provides the necessary frequency response shaping and level shifting to provide a quality mono signal from mono prints. In addition, a special open ended noise reduction circuit called Dynamic Noise Reduction is used to eliminate much of the "hiss" and film scratch noise often present on film. This card also provides the necessary drive signal for the optional stereo synthesizer portions of the MOD V.

The MONO card contains the necessary circuitry for the emergency backup system in the event of loss of sound within the MOD V processor. The multi-turn pot on this card is for setting the emergency backup level.

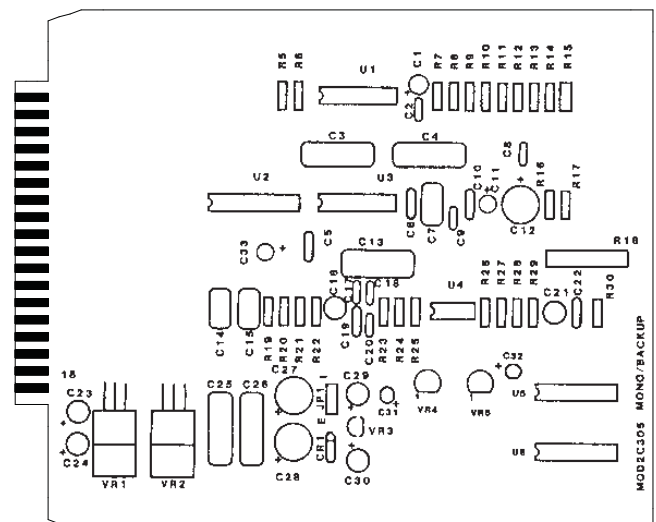

MATRIX CARD: MOD4X317

This is the heart of the stereo conversion process. The Wide Trac Deluxe Matrix card takes the signal from the preamp and noise reduction circuits and converts the two channel soundtrack into the four channels required for normal stereo mode. There is a surround null adjustment trimpot on the matrix card which the installer can adjust to minimize surround channel crosstalk without disturbing the input signal calibration settings of the preamplifier and noise reduction circuits.

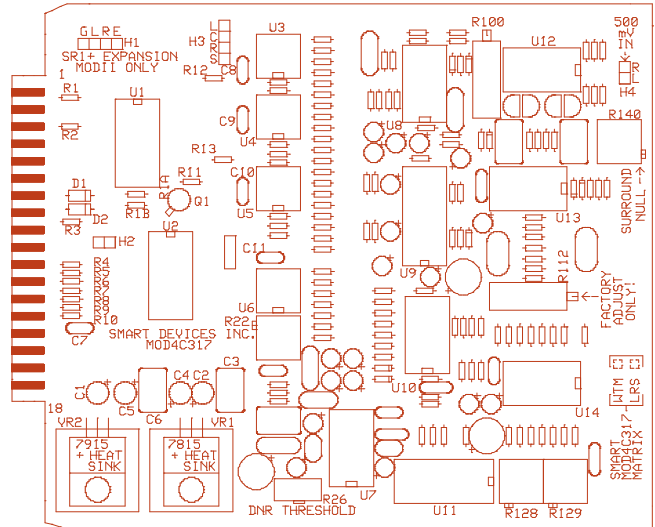

1/3 Octave EQ

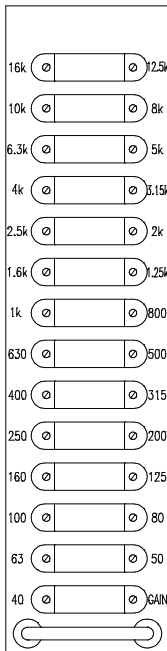

One Octave EQ

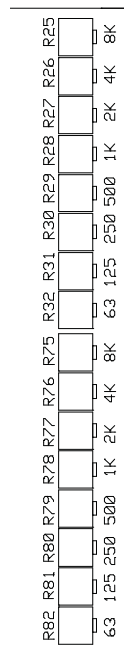

1/3 OCTAVE EQUALIZER CARDS: MOD4X320

Three one third octave room tuning equalizers are used for the front stage speakers. Each adjustable frequency band in the front stage EQs may be cut or boost ± 10 dB. A +6 dB gain adjustment is also on each card. For overall unity gain, leave the gain pot in the CCW position. For unity gain on each of the frequency band adjustments, leave the pot in the mid position. All pots are the single turn type.

DUAL CHANNEL ONE OCTAVE EQUALIZER CARD: MOD4X324

This card is for the Left and Right Surround Channels. Circuitry and operation is similar to the stage channel EQs except that it uses one octave EQs and there is no gain adjustment pot. The top eight trimpots are for Left Surround, and the bottom eight are for Right Surround.

DIGITAL TIME DELAY/SURROUND GENERATOR CARD:

MOD5X325

The digital time delay portion of the MOD V system is contained on this card, along with the optional Stereo Generator Surround Module. The surround channel passes through the time delay whenever any Stereo-Optical format or Stereo Generator format is selected by the operator. 35mm magnetic, 70mm magnetic, Music or digital inputs are NOT time delayed. There is a rotary switch on this card that is used to set the time delay setting. The rotary switch has 16 positions: 0-9 & A-F. Position 0 is 10 milliseconds of delay, which is the minimum delay setting. Each position clockwise adds 10 milliseconds of delay for a maximum setting of 160 milliseconds (position F).

Note: Earlier units used an analog time delay card. This card had dip switches that set the time delay. All switches down (on position) produced a minimum delay of 35 milliseconds. Each dip switch flipped up (off position) added 10 milliseconds of additional delay.

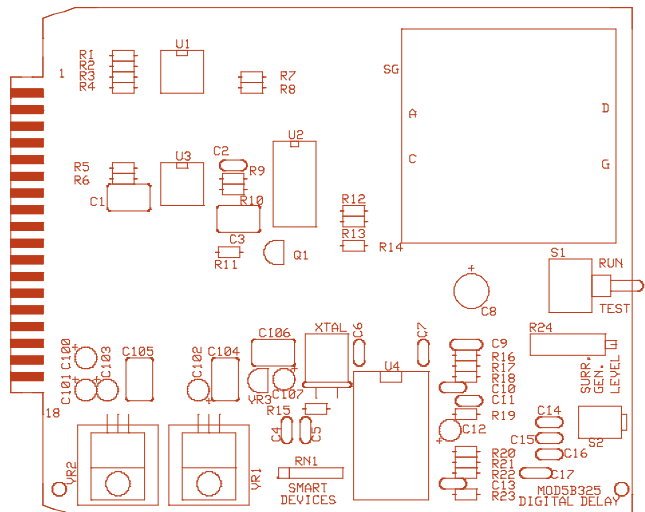

**OUTPUT/MUSIC CARD:
MOD5X331**

Eight channels of audio, comprised of the primary stereo channels (Left, Center, Right, Sub, Left Surround and Right Surround), along with the Left-Extra and Right-Extra channels, pass through the MASTER VCA (Voltage Controlled Amplifiers). The digital inputs also allow for separate Left Surround and Right Surround channels in addition to a separate subwoofer input. The VCAs exhibit very close tracking between channels and are controlled by the MASTER FILM FADER and individual FORMAT LEVEL TRIMS contained on the front panel. Music Fade-in and Fade-out, controlled by the automation or front panel format switch, is also on the output card along with a special music matrix to generate a four channel non-sync sound from a standard two channel music tape or CD player.

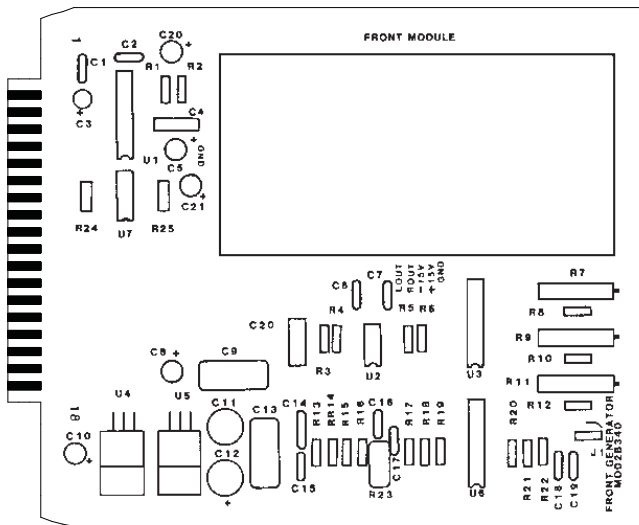
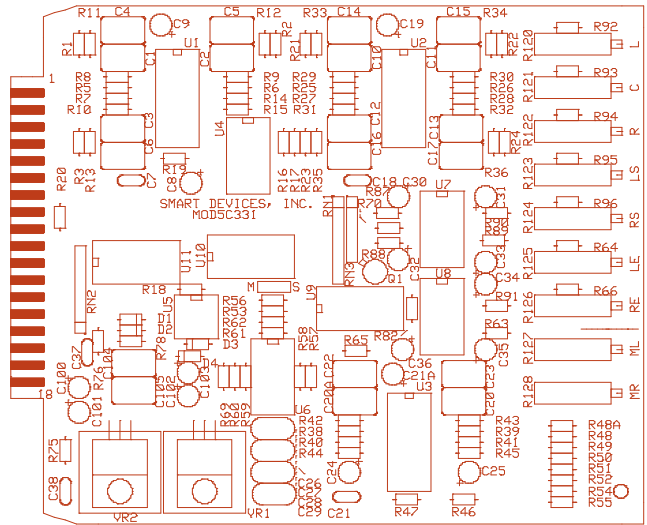

**FRONT STEREO GENERATOR CARD (optional):
MOD2X340**

A deluxe Stereo Generator (synthesizer) is offered as an optional feature of the MOD V system. The synthesized front channel circuits are included on this card. The optional surround generator is part of the DELAY/SURROUND GENERATOR card in another part of the system. The output levels for the three stage synthesizer channels should be adjusted ONLY after the main stereo-optical channels have been correctly adjusted. The synthesizer levels should be set to be the same as other stereo channels so that a transition between film format modes will appear smooth to the audience without large level changes. Three multi-turn pots are located on the front of the Stereo Generator PC board to adjust the Left, Center, and Right channel outputs.

**SUB WOOFER/BASS EXPANDER CARD:
MOD5X346**

The last PC board on the far right of the MOD V card cage contains the subwoofer output circuitry and the EMERGENCY BYPASS switch. Switching the MOD V into emergency bypass mode is as simple as flipping the red bypass switch. The bypass audio level is set by a multi-turn pot on the Mono Backup card.

This card is equipped with an optical expander circuit that works only when optical sound formats have been selected (Stereo, SR & Stereo Generator), and not on Magnetic, Digital inputs, or non-sync music. The small ON-OFF toggle switch on the front of the PC board turns the subwoofer circuit on or off. The Sub-Bass optical expander expands the output level at a 1.5 to 1 ratio in the low frequencies.

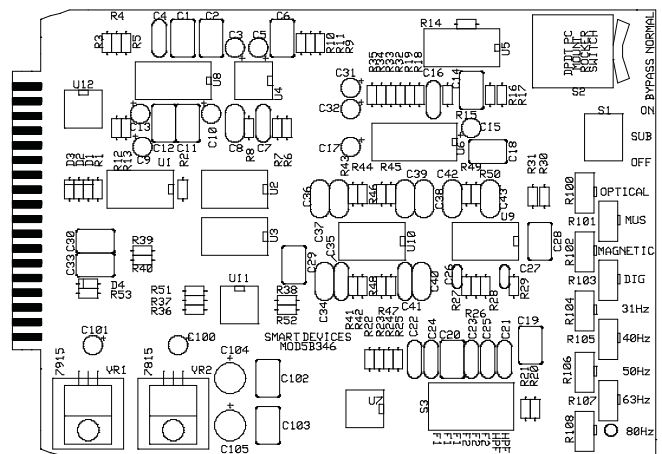

The Sub-Bass card is equipped with a five band 1/3 octave equalizer. The frequency adjustments are 31, 40, 50, 63 and 80 Hz. This gives good coverage of the sub-bass region.

Bandpass shaping for the low frequency subwoofer output is selectable with various settings of the DIP switches at the front of the PC card. The High Pass filter has a fixed slope of 12 dB/octave, and the Low pass filter is 18 dB/octave. The following combinations of switches will configure the filters for the desired LF bandpass output.

DIP SWITCH SETTINGS FOR VARIOUS FREQUENCY BANDPASS CHARACTERISTICS

ALL switches UP for wide-band frequency response. Useful when feeding a sub-woofer power amplifier that has built-in filters.

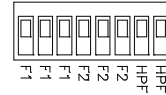

ALL F1 switches DOWN - ALL other switches UP for 10-65 Hz response to sub-woofer output.

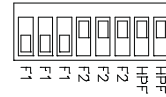

F2 switches DOWN with ALL other switches UP will give a 10-200 Hz response.

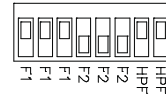

ALL F1 switches and HPF (high pass filters) DOWN, with F2 switches up for 25-80 Hz frequency response.

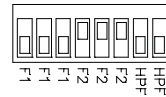

ALL F2 and HPF switches DOWN with F1 switches up results in 35-225 Hz bandpass.

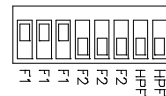

If ALL DIP switches are set to the DOWN position, the output response will be 23-68 Hz.



The Subwoofer/Bass expander card has individual output level adjustments for Optical, Digital, Magnetic, and Music Formats. Each format sub-bass level may be set separately.

INSTALLATION INSTRUCTIONS

PROCESSOR PLACEMENT IN THE RACK:

Before mounting the MOD V processor in the equipment rack or projector console, be sure to select a well ventilated area that allows cool air to circulate around the individual components. In SMART prewired rack systems, the Power Supply is mounted on the floor of the rack, and the rack-mounted processor is placed at eye level for easy visibility of the system operation status.

Make sure that the processor is not immediately adjacent to hum producing components. Run the factory-supplied power supply wiring harness along the left side of the equipment cabinet (when viewed from the rear) to the MOD V processor. Dress the wires for appearance and craftsmanship. The wiring harness has a connector that plugs into the back of the MOD V. Make sure to observe polarity. As you are looking at the back of the MOD V, the far left connector is where the power supply harness plugs in. The power supply wires will exit from the bottom of the connector. The red wire should go to the terminal marked +20 VOLTS, the black wire to PS GROUND, and the yellow wire to -20 VOLTS. Remember to check all connections before applying power to the system. A wire that is reversed could be very destructive to the system.

EMERGENCY SUPPLY:

The emergency power supply is contained within the Main Power Supply. There is a white wire with a red stripe that is

part of the power supply harness and it should be connected to the MOD V terminal marked BYPASS DC, and the black lead should connect to the terminal marked BYPASS GND.

WIRING HOOKUP INSTRUCTIONS:

EASY HOOKUP:

All connections are made to rear of the MOD V with plug-in Entelec connectors (supplied). Inputs, Outputs, Power and Control connections are carefully laid out in groups. Please do not bundle the wires together with tie-wraps. Make sure each group has good separation between low-level and high-level signals.

SOLAR CELL HOOKUP:

Connect the wire from the left solar cell (red) to the corresponding LEFT projector input terminal of the MOD V. Connect the wire from the right solar cell (green) to the RIGHT projector input terminal. The common solar cell lead (black) should be connected to the NEUTRAL projector input terminal, and the shield of the cable to the GROUND terminal. Be sure to cut off the shield at the projector end so that a ground loop is not created. Only the shield on the MOD V end of the cable should be grounded. It is good practice to tape or shrink wrap the end of the shielded cable at the sound head to prevent any stray shield wires from grounding out to the sound head case.

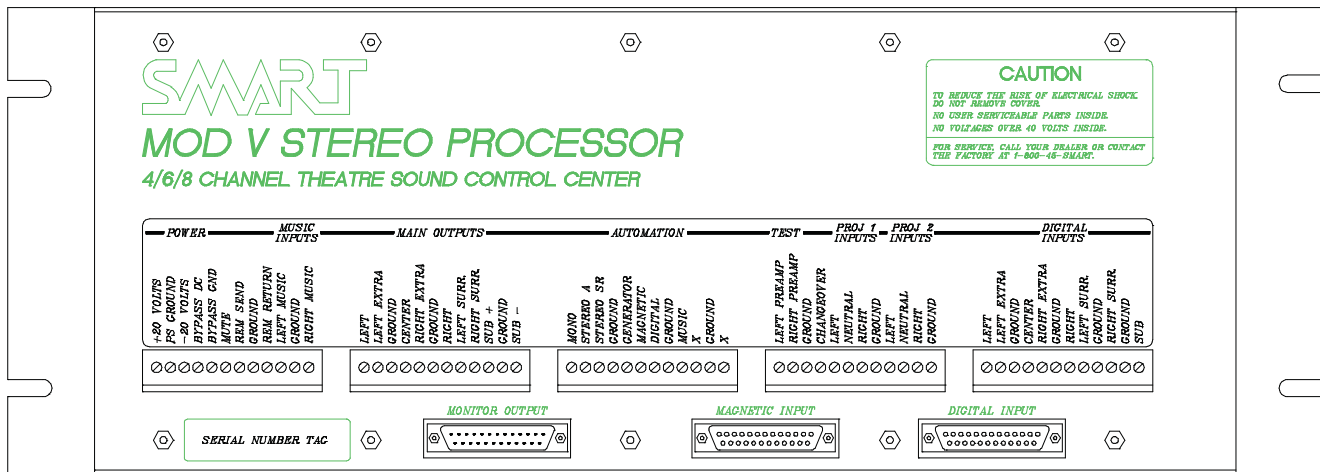

CAUTION
 TO REDUCE THE RISK OF ELECTRICAL SHOCK,
 DO NOT REMOVE COVER.
 NO USER SERVICEABLE PARTS INSIDE.
 NO VOLTAGES OVER 40 VOLTS INSIDE.
 FOR SERVICE, CALL YOUR DEALER OR CONTACT
 THE FACTORY AT 1-800-46-SHARR.

DOUBLE CHECK your work to see that the solar cell leads arrive at the proper terminals. A reversal of leads will cause very strange results. You may hear the center channel information through the surround speakers, the surround through the stage, and the left channel out of phase with the right. This is a common error, so verify correct wiring before proceeding.

AUTOMATION TERMINALS:

A momentary ground contact to one of the format terminals on the automation inputs of the MOD V will switch the processor to any desired format, including music. When the MOD V is in music mode and any one of the film formats are pulsed, the film sound will appear at the main outputs, and the music will slowly fade out. While the processor is in one of the film formats and the music terminal is pulsed, the MOD V will fade from the film mode to music.

OUTPUTS:

The 8 channel outputs are labeled LEFT, LEFT EXTRA, CENTER, RIGHT, RIGHT EXTRA LEFT SURROUND, RIGHT SURROUND, SUB+ and SUB-. Shielded cable should be run between these terminals and the next piece of equipment in the sound system (equalizer, amplifier, etc.). Convenient GROUND terminals are provided near the outputs. A balanced subwoofer output is available on the MOD V. The balanced output provides an easy means to mono bridge the sub amplifier.

CHANGE OVER WIRING OF DUAL PROJECTOR PRE-AMPS:

Changeover between projectors is done electronically in the MOD V. This necessitates that BOTH exciter lamps be lit at the same time. No exciter light changeover is provided in the unit. An exciter light changeover has at least 3 dB more circuit noise than an electronic changeover and is NOT recommended in high quality systems.

Projector changeover is accomplished by using only a single pair of wires and either a manual switch or relay contacts in the automation system. A relay closure in the automation equipment will execute a changeover by grounding the CHANGE OVER terminal. Run a pair of twisted unshielded wires to the "dry" contacts of the automation projector changeover relay. Connect one wire from the other end of the pair to the CHANGE OVER terminal of the MOD V only. Ground the other wire of the pair to the nearest ground terminal on the MOD V. When the automation relay closes,

projector TWO of the MOD V will be "enabled," and the first pair of stereo preamplifiers (PROJ 1) will be "disabled." Releasing the relay will cause the reverse action to occur. In other words, PROJ 1 is always ON until the CHANGE OVER terminal is grounded. The CHANGE OVER terminal must be held low to activate PROJ 2. It is not a pulse input.

DIGITAL INPUTS:

The MOD V system has 8 inputs on the rear barrier strip labeled for each channel of a digital decoder. There is also a DB25 input connector that can be used for digital inputs (see the REAR CHASSIS DB25 SECTION for specific pinout designation). The Digital inputs accept any high level multi-channel source and route the signals through the MOD V, which includes the Master Fader and EQs.

Another application of the Digital Input terminals is for external sync sources. Sound-Interlock from a 35mm reproducer or a single 16mm projector may be fed into the Digital inputs and selected with the front panel DIGITAL program switch on the MOD V front panel.

MUSIC INPUT:

The non-sync music inputs for the MOD V feature a special music matrix decoder that separates in-phase and out-of-phase signals on a standard two channel recording (CD player or tape) and creates four channels of auditorium music. Connect your stereo music source to the LEFT and RIGHT MUSIC inputs on the MOD V.

Occasionally, a theatre may use a monaural sound player such as a background music cartridge player that does not have stereo capabilities. A jumper on the OUTPUT CARD in the MOD V is moved to the MONO position for this use. The music source should then be connected to both LEFT and RIGHT MUSIC inputs. Music will appear on all stage channel and surround speakers when mono material is feeding the sound system.

REAR CHASSIS DB25 CONNECTORS:

The computer type DB25 connectors on the back of the processor are for special inputs and outputs. On the far left (as you view the rear of the chassis) there is a DB25 connector that provides monitor outputs of all channels for a THX booth monitor/crossover package. Output pinout of the DB25 connector is compatible with a THX monitor. You may use a shielded SERIAL computer cable to make

the connection between the MOD V and a THX monitor. The cable should have a male DB25 on one end, and female on the other end. You must use a cable in which all pins of the DB25 are connected. Some computer cables do not connect all pins. The middle DB 25 connector provides inputs for 70mm magnetic signals from external preamps. The far right DB25 connector is an alternative input connection for a digital decoder (i.e. DTS, Dolby Digital). See below for specific pinout configuration.

The MONITOR DB25 outputs:

Pin 2	Left
Pin 16	Left Extra
Pin 5	Center
Pin 8	Right
Pin 19	Right Extra
Pin 23	Left Surr.
Pin 24	Right Surr.
Pin 25	Sub+
Pin 12	Sub -
Pins 3, 10, 11, 14, 17 & 20	Ground

The MAGNETIC DB25 inputs:

Pin 1	Left
Pin 2	Center
Pin 3	Right
Pin 4	Surround
Pin 5	Left Extra
Pin 6	Right Extra
Pins 14-20	Ground

The DIGITAL DB25 inputs

Pin 1	Left
Pin 3	Center
Pin 5	Right
Pin 6	Left Surr.
Pin 7	Right Surr.
Pin 8	Sub
Pin 12	Digital
Pin 13	Stereo A / Stereo SR *
Pin 14	Ground

*see Default Optical Selection below

DEFAULT OPTICAL SELECTION:

External Digital Decoders available on the market (i.e. DTS) have a function that instructs the processor to switch to an optical format in the event that the digital decoder fails or loses time code. When this happens, the digital decoder will pulse a special terminal to ground to alert the processor to switch to the optical format.

On the MOD V Digital DB25 input connector, this terminal is the Stereo A / Stereo SR pin (see above). The MOD V will switch to either Stereo A or Stereo SR depending on the location of a 0 ohm resistor jumper located on the lower right side of the back motherboard.

The MOD V is shipped to default to Stereo A in the event of a digital decoder problem. In this default mode, J1 has a 0 ohm resistor installed and J2 does not. For a default setting of Stereo SR, you must remove the 0 ohm resistor jumper on J1 (it must be desoldered) and one must be installed on J2 (soldered in place). The factory default setting of Stereo A should be adequate for most theatres. However, if a Stereo SR default is desired, then all plug-in cards must be removed along with the internal tray in order

to access the back motherboard. Use extreme care when removing and plugging in the circuit cards. Make sure power is removed from the system before doing so.

MUTING FUNCTION:

A convenient mute terminal on the back of the MOD V allows all output channels of the MOD V to be silenced whenever this terminal is grounded.

Note: On earlier units, the MUTE terminal was mistakenly marked as GROUND. This terminal is the sixth one from the left on the far left entrelec connector as viewed from the rear of the MOD V.

REMOTE FADER OPERATION:

The volume control of the MOD V can be operated remotely at another location, independent of the MASTER FILM FADER. This can be accomplished by adding a remote, linear taper 10k ohm pot (to act as a volume control) between the REM SEND and GROUND terminals on the back of the MOD V. Connect the wiper of the remote pot to the REM RETURN terminal. (See diagram.)

The toggle switch on the left hand side of the front panel display board, labeled VOLUME SELECT, allows the operator to select either local or remote volume control of the MOD V. This switch is easily accessible by opening the hinged front panel.

Note: Remote operation is for film formats only, and will not affect the music level.

GROUNDING

On the left rear side of the MOD V (see below), next to the power supply terminals, a special ground wire has been added to allow jumpering of the MOD V circuit ground to the system chassis ground. Normally, this wire is left unconnected which separates circuit ground from chassis ground. In most cases, this will result in the least amount of ground loop problems.

In the event of ground problems, this wire may be connected to any terminal marked GROUND on the rear of the MOD V. This will then jumper the circuit ground to chassis ground. Take special caution when diagnosing ground problems; what may work with one sound system may not necessarily work with another.



Rear view of MOD V showing the special ground wire.

CALIBRATION

The Sound Systems should be turned on for at least one hour before alignment. All doors should be closed and the exhaust fan should be running if the MOD V is placed in an equipment rack.

Note: Before plugging or unplugging cards in the MOD V during calibration, be certain power is removed from the MOD V. Otherwise, damage to cards or the processor may result!

EQUIPMENT REQUIRED:

Sound Pressure level meter, real time analyzer with a calibrated microphone, dual trace oscilloscope, multimeter, a tuning wand and appropriate test loops.

B CHAIN CALIBRATION:

PRELIMINARY:

It is desirable to have a SMART PINK NOISE GENERATOR CARD and, optionally, an EXTENDER CARD for performing the calibration and testing of the MOD V. Note: Make sure the SMART Pink Noise Generator Card has the following minor modification: There must be a jumper wire between pins 4 & 5 of the edge connector as viewed from the component side. This allows the Surround switch to simultaneously feed pink noise to both Left and Right Surround channels. A future version of the Pink Noise Generator card will have separate Left and Right Surround switches.

The PINK NOISE card may be plugged directly in without the extender card, but it is easier if the extender card is used with the PINK NOISE card. The PINK NOISE card plugs into the MATRIX CARD position for setting house EQ levels and into the PREAMP CARD position for setting sub-bass levels. The PINK NOISE CARD has seven switches. The bottom switch is used to select NORMAL or CHOO-CHOO modes. The top six switches are used to turn individual channels on and off. These channel switches are three position, with center position being off, the top position giving an in phase signal and the bottom position giving an out of phase signal. There is a built-in high quality pink noise source which feeds these switches.

If a Pink Noise Card is not available for the MOD V calibration, then an external pink noise source may be used instead. Feed the external pink noise source into the DIGITAL inputs on the rear of the MOD V for the following

ISO Cinema playback standard states that 1/3 octave bands should be tuned for flat response to 2 kHz, with a 3 dB/octave rolloff above 2K.

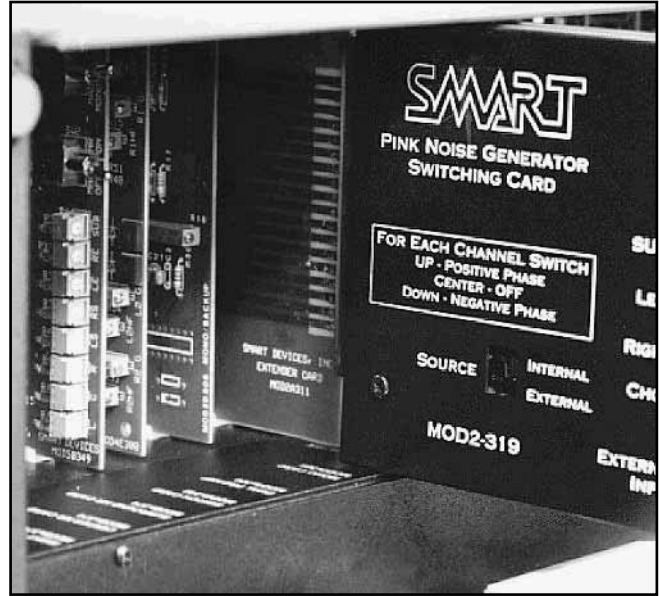
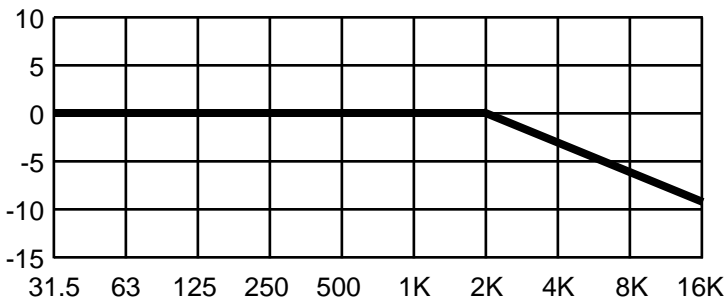

The optional extender card can be used with the Pink Noise Card to calibrate the MOD V. This allows easier access to the Pink Noise Card.

checks. Set the pink noise source level for .55 volts RMS. You must use an analog meter to measure this voltage level. **Special Note:** The factory settings for digital levels on the External Input/NR Switching Card should be left as they are while using an external pink noise source. This will ensure that the house levels are set correctly. Normally, the digital input levels on the External Input/NR Switching card do not need adjustment, but if they must be adjusted, do so AFTER setting house levels. See the DIGITAL LEVEL SETTINGS at the end of the B CHAIN CALIBRATION section for more information.

For the following procedures, select STEREO by pushing the appropriate button on the front panel. Also, set the front panel MASTER FILM FADER to the CAL line, and the trim faders to the 12 o'clock position.

EQUALIZATION AND HOUSE LEVELS:

The equalizers are normally shipped with the individual trimpots set for a flat frequency response. The 1/3 octave equalizers used for the stage channels are capable of cutting and boosting each frequency band ± 10 dB. The individual trimpots are single turn types, with the mid position of each pot being flat (unity gain).

The dual-channel surround equalizer card is a full octave band type. All frequencies on this card are also cut and boost ± 10 dB with single turn trimpots.

Remove the MATRIX CARD from its slot and set it aside. Plug the PINK NOISE CARD into the MATRIX CARD slot. Make sure the NORMAL/CHOO-CHOO switch is in the NORMAL position. Turn on the appropriate switch on the PINK NOISE CARD for the channel you wish to equalize. Perform the equalization and then adjust the output trimpot on the OUTPUT/MUSIC CARD so that 85 dBC spl is measured in the auditorium. Do this for the five main channels (Left, Center, Right, Left Surround & Right Surround). If more gain is needed, then the gain pot on the

stage EQs can be used which gives an additional 6 dB of gain. However, do not boost the gain on the EQ cards unless it is absolutely necessary.

The 1/3 octave stage channel equalizers in the MOD V allow the same tuning results obtained in professional room tuning filter sets used in high-end sound playback applications. Sound contractors learned, a long time ago, that boosting frequency bands adjacent to bands that are cut introduce a phase shift that the ear is very sensitive to. Although the test instruments show a nice curve, the sound has a coloration that is not natural. *For this reason, we encourage you to apply the minimum amount of boost and cut whenever needed. Never over-equalize the system.* All frequencies may be cut and boosted by as much as 7 dB in each of the 1/3 octave bands without creating the above problems. The use of bass and treble controls on the equalizer has also been avoided to further minimize phase shift. Each filter section uses a single turn trimpot for adjustment. The equalizers are factory set for flat response during final QC test.

Before attempting to equalize be sure the stage speaker connections are properly polarized, the polarity of the components in each speaker system is correct, and the speaker devices are mechanically aligned according to the manufacturer's recommendations. Remember that equalizers are used to tune the room, NOT to correct poor speaker installation and alignment.

If LE and RE are being used, turn on the pink noise for these channels (one at a time) and adjust the output trimpots for 85 dBC spl. There are no equalizers for the LE and RE channels.

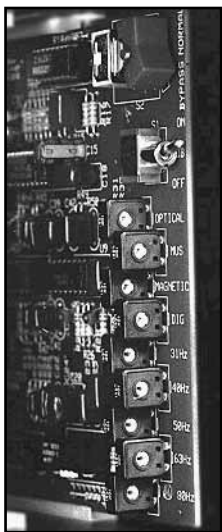

SUB-BASS LEVELS:

Remove the PREAMP CARD from its slot and set it aside. Remove the PINK NOISE CARD from the MATRIX CARD slot and plug it into the PREAMP CARD slot. Do not plug the MATRIX CARD back in yet. Turn on the LEFT and RIGHT pink noise switches. Adjust the individual EQ adjustments on the Sub-Bass Card for a flat low frequency response from the subwoofer. Each EQ pot allows a ± 10 dB range. Adjust the OPTICAL LEVEL trimpot on the Sub-Bass Card for 90 dBC spl from the subwoofer. In Music or Mag modes, adjust Music or Mag pots for the desired sub levels. In Digital mode, set Dig sub pot per digital processor instructions.

OPTIONAL GENERATOR FUNCTIONS:

If your MOD V is equipped with the optional stereo and surround generator modules, then do the following adjustments:

Install the J1 jumper on the Front Stereo Generator Card to the rear two pins to prevent high frequency attenuation when in Generator mode. Insure that the Pink Noise Generator Card is plugged into the preamp slot. Switch on the pink noise for the Left and Right channels (in phase), and flip the Digital Time Delay/Surround Generator Card switch to the TEST position. Turn the surround amp off.

Now adjust the Left, Center and Right generator levels on the Front Stereo Generator Card to read 82 dBC in the auditorium. To do this, switch the power amplifiers off and set gains one channel at a time, by switching on only the amplifier for that channel being adjusted. Once stage levels are balanced, switch all power amps on and check to insure that a sound pressure level of 85 dBC is obtained. Turn off the stage amps and turn on the surround amp. Adjust the level pot on the Digital Time Delay/Surround Generator Card for an auditorium level of 85 dBC. Flip the RUN/TEST switch back to RUN and turn all amps back on. Remove the Pink Noise Generator Card.

Plug the MATRIX and PREAMP Cards back into their appropriate slots.

MUSIC LEVELS:

Set the MUSIC LEVEL control on the front panel to the 3 o'clock position. Select Music mode and turn on the music source that is feeding the MOD V. Turn the left and right music level trimpots on the Output/Music Card to obtain a normal house level. These trimpots are factory set and may not need adjustment. **DO NOT TURN THESE UP TOO HIGH** as music-to-film crosstalk may occur. Adjust the trimpots so that right and left music are set to the same level. The music circuit in the MOD V has a simple matrix which generates four channels of music from any 2-channel stereo music source.

TIME DELAY:

Locate the 325 DIGITAL TIME DELAY/SURROUND GENERATOR Card. The bottom of this card has a rotary switch. Each position clockwise on the rotary switch equals 10 mSec (milliseconds) of delay. Position 0 is the minimum delay setting which equals 10 mSec of delay. Position 1 produces a total of 20 mSec of delay, position 2, 30 mSec, etc. The maximum amount of delay possible is 160 mSec. Measure the distance in feet from the ideal seat (which is usually 2/3 of the way back from the stage speakers, centered side to side) to the stage speakers. Now measure the distance from the ideal seat to the nearest surround speaker. Subtract the two measurements. Now add 20 to this number to get the delay (in milliseconds) required in the auditorium. Set the rotary switch to the nearest setting in milliseconds.

POSITION	DELAY
0	10
1	20
2	30
3	40
4	50
5	60
6	70
7	80
8	90
9	100
A	110
B	120
C	130
D	140
E	150
F	160

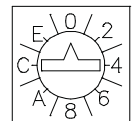

DIGITAL LEVEL SETTINGS:

Incoming signals from the Digital input terminals SHOULD be trimmed externally to match levels from the Stereo-Optical signals. These adjustments can be made at the output of the external digital processor or interlock audio tape machine (see manufacturer's manual). If necessary, additional digital level adjustments can be made on the MOD V EXTERNAL INPUT/NR SWITCHING CARD, which has eight trimpot adjustments for cutting or boosting the input level of each individual digital channel. Normally, this card is set for unity

gain. Make sure that all other B-chain calibration adjustments have been made prior to adjusting the digital input levels on the External Input/NR Switching Card (see special note in the PRELIMINARY section of the B CHAIN CALIBRATION).

A CHAIN CALIBRATION:

PRELIMINARY:

1. Clean soundhead optics, exciter lamp, optical lens and solar cell before attempting a soundhead alignment.
2. Set exciter lamp voltage for at least 80% of rated voltage.
 BXM 9 volt 4 amp — 7.2 volts
 BXN 10 volt 5 amp — 8 volts
 Most foreign 6.3 volt 4 amp — 5 volts
3. Make sure film/cell spacing is approximately 1mm with the slit image striking the top one-third of solar cell.
4. Connect scope and real time analyzer to the left and right preamp outputs on the rear terminals of the MOD V, or at the test points (mini-banana jacks) on the front panel display board.
5. Locate gain controls on 300 Preamp Card. Turn gain controls fully clockwise.
6. Turn the MASTER FILM FADER all the way down to avoid excessive noises in the auditorium for the next steps.

SOUNDHEAD ALIGNMENT:

1. Play a S.M.P.T.E. Buzz Track loop. Adjust the lateral film guide assembly or exciter lamp assembly. Monitor the preamp signals with the oscilloscope. Adjust for minimum signal on the left and right channels. Refer to specific instructions in the projector soundhead manual. Minor variations in alignment procedure depend on the individual mechanical design of the soundhead.
2. Play CAT.# 97 Stereo Cell Alignment Film. Move solar cell laterally and vertically until you have achieved minimum crosstalk between channels (see above right).
3. Repeat steps 1 and 2 until no further improvement can be obtained.
4. Play Pink Noise side of CAT.# 69 Test Film. Switch scope to X/Y Mode. Adjust soundhead optical lens azimuth for narrowest diagonal trace. Observe the real time analyzer and focus the lens for maximum high frequency output while maintaining the best azimuth. This is not easy, but it is one of the most critical adjustments affecting the overall system performance and is often not done as well as it should be.
5. Adjust the vertical and lateral alignment of the EXCITER LAMP for maximum output on both channels. This is especially critical with a narrow slit optical lens because there is a much smaller “window” for the light to pass through.
6. Check the high frequency output on both channels. Make

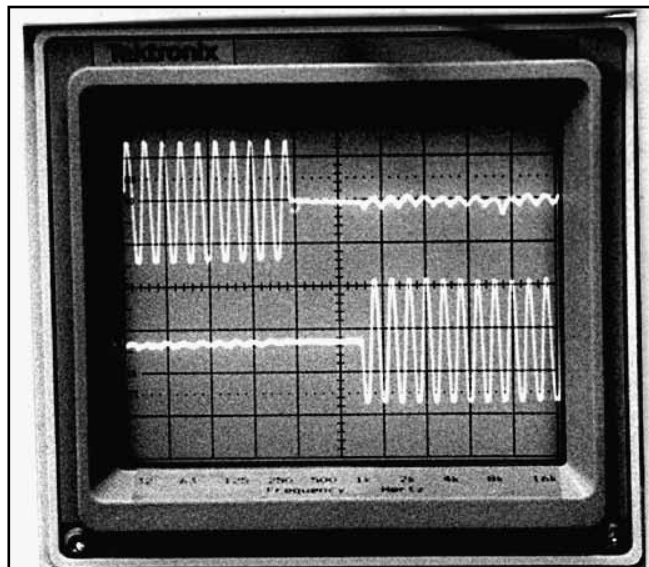

Low crosstalk between channels.

sure the response is the same on both channels. With a **narrow slit** optical lens, the response should be flat within ± 3 dB to about 12 kHz with NO slit loss correction. If not, this **MUST** be corrected before proceeding with the next steps. It is not permissible to use slit loss correction to correct poor high frequency response caused by misalignment of the optical soundhead. An EXCITER LAMP out of alignment, the barrel of the optical lens crooked, or oil in the optical lens will all affect output and balance.

OPTICAL PREAMP CALIBRATION:

Run the pink noise side of the CAT. # 69 loop. Observe the frequency response on your RTA which is still connected to the preamp testpoints. Adjust the left and right slit loss correction trimpots on the PREAMP CARD for optimum flat high frequency response. Do not over adjust the slit loss correction in an effort to obtain extended response. This will result in an undesirable frequency response peak.

Note: While adjusting the slit loss correction, aim for as flat a high frequency response as possible. If one of the preamp channels is slightly worse than the other, then adjust the better responding preamp to match the lesser. This will ensure that the matrix steering in the MOD V will be as accurate as possible.

While running the Dolby CAT. # 69 loop, tone side. Observe the preamp calibration LED's on the front panel display board. These LED's are located near the right front of the display board, component side. Adjust the LEFT and RIGHT trimpots on the PREAMP CARD until both LED's



The preamp calibration LED's

for left and both LED's for right are on simultaneously. There are preamp testpoints located just to the right of the calibration LED's to which you may hook up an AC voltmeter to accurately measure the preamp levels. The correct level for Dolby tone is 707 mV AC.

SURROUND NULL:

Make sure the MATRIX CARD is plugged back into its slot. Set the SURROUND NULL switch on the Front Panel Display Card to ON. While running the CAT. # 69 Dolby tone adjust the NULL trimpot on the MATRIX CARD for a minimum signal observed on the Left Surround LED array on the front of the MOD V. Switch the Surround Null back to off when finished.

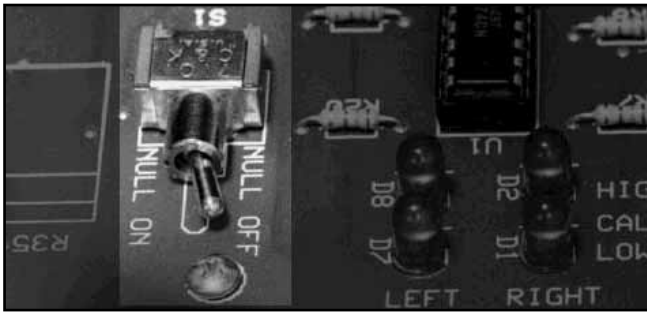

BYPASS:

Listen to the CENTER channel on the booth monitor. Switch from normal to backup (the Red switch on the Sub-Bass Card) and adjust the backup level pot on 305 Mono Card to achieve equal levels while switching from Normal mode to Backup mode while running a film soundtrack.

This completes the "A" Chain and BYPASS calibrations.

OPERATING INSTRUCTIONS

The MOD V system is one of the easiest systems to operate. The Manager/Operator of the sound booth should review the operation instructions to assure that emergency functions are also understood, should they ever be needed.

TURNING ON THE SYSTEM:

The sound engineer who installed the sound system has provided a way to apply power to the system through a master power switch or circuit breaker. Also, several of the individual components in the equipment rack have their own power switches. Become familiar with all switches or breakers that control power to the sound equipment.

If the components are normally turned on individually, it is important that the processing components are turned on first and the power amplifiers are turned on after all other components are on for a few seconds. This will allow time for the low level circuits to stabilize so that the power amplifiers will not pass a "turn-on thump" to the auditorium speakers. Repeat in reverse order when turning off the system.

MUSIC SELECTION:

It is likely that the sound system will be turned on before the arrival of the first audience of the day. The MOD V powers up in Music mode. If the music player (CD player or tape machine) is running, music will be heard in the auditorium

and on the booth monitor. MUSIC may also be selected by pressing the front panel Music button.

PROGRAM SELECTION:

The automation should be set to select the proper formats when needed. However, any format may be overridden by simply pushing one of the Format buttons located on the front of the MOD V.

EMERGENCY BYPASS SWITCH:

The MOD V contains a backup system that will keep the show sound on the screen in the event of a failure of the processor. This special circuitry is located on the MONO card in the main card cage unit and is activated by the red NORMAL-BACKUP switch located on the Sub-Bass Expander card at the far right slot in the MOD V chassis.

MASTER FILM FADER:

This control is located on the MOD V Front Panel and is used to set the system level for any film format, but not for music level.

FORMAT LEVEL TRIMS:

These front trim controls can be used to make minor volume changes to any of the formats. The MUSIC control serves as the master fader for music level, and is a full range volume control.

AUTOMATIC SURROUND GENERATOR:

The MOD V system may contain an optional surround generator for monaural soundtracks when the system is placed into the GEN mode of operation. This circuit needs no adjustment by the installer or operator.



The front of the MOD V is where the Master Film Fader, Format Level Trims, Format Select Buttons, and individual channel LED indicators are located.

SERVICE

CAUTION:

Service instructions are included for use by qualified personnel only. To avoid electrical shock, do not perform servicing other than that described within the Operating Instructions unless you are qualified to do so. Refer all such servicing to qualified service personnel.

Repairs to this product should be performed in accordance with applicable safety standards, and should be performed only by a trained service technician.

Most components used in the MOD V are available locally

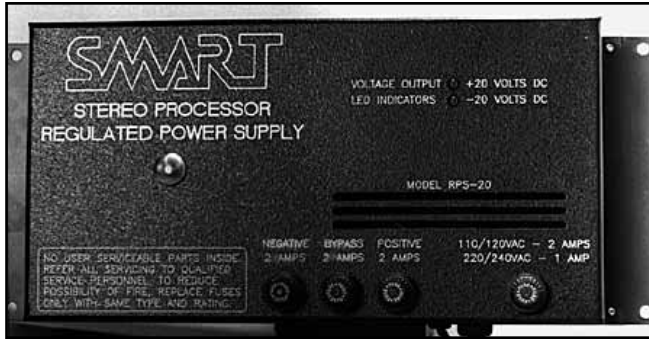

The MOD V Power Supply should be the first item checked when troubleshooting the MOD V system.

from a radio parts supplier. Refer to the schematic diagrams for information regarding specific circuits. IC sockets are used to facilitate easy removal and replacement of any Integrated Circuit, should this ever become necessary.

Each unit is “burned in” for a minimum of 5 days before Q.C. testing and packaging. This ensures that the MOD V purchased by the customer will be free of defect. However, in the event of a failure of one or more functions of the MOD V, a service call will result by the owner. Before calling the unit defective, always check for obvious causes of the symptoms first:

1. Is the unit receiving AC. power? (Control panel lit.)
2. Has the power supply fuse blown? (Replace with applicable fuse type and rating.)
3. Are all controls in their normal operating mode?
4. Is the supporting equipment functioning properly? (Amplifiers, equalizers, exciter lamp supply, etc.)

When all symptoms point to an internal problem, your only choice is to substitute with a spare (or similar piece of equipment) and have the unit fixed by SMART Devices or another competent repair facility.

TROUBLESHOOTING:

A quick check of the power supply voltages will indicate if the power supply is operating properly. Place your service meter negative lead on a convenient GROUND point (such as a terminal strip ground). Switch your voltmeter to the PLUS 30 volt DC range or higher and measure the positive voltage input at the power supply terminal on the MOD V. It should be 20 volts DC. Now measure the negative voltage from the power supply. It should be -20 volts DC. If you cannot obtain the voltages mentioned, you may have a shorted connecting cable or a bad power supply.

Disconnect the low voltage cable by unplugging the power plug at the processor end and make the tests again on the power supply terminals. **BE CAREFUL NOT TO SHORT THE PINS ON THE POWER SUPPLY TERMINALS WHILE MAKING THESE TESTS. A MOMENTARY SHORT COULD PRODUCE A DANGEROUS SPARK BEFORE THE SUPPLY GOES INTO SELF-PROTECT.**

When you are satisfied that the voltages are correct, go to the schematic diagram and study the circuit layout. The

most practical way to troubleshoot audio circuits is through signal tracing. Put an audio signal into the input and follow the signal with a scope until the signal stops. This method allows you to locate a defective component in the related section.

Since the MOD V uses a bi-polar supply, each audio IC opamp output should measure nearly 0 volts DC with no signal. That is, you should be able to probe each output pin with your service meter and see a minimum DC offset. If the opamp is showing a few volts at the output pin, it is likely that a bad capacitor or resistor is causing an input bias that forces the output of the amplifier to shift. A defective IC could also be the culprit. Note: **SOME OF THE IC's OPERATE ON A SINGLE-ENDED SUPPLY.** These chips get their current from the positive supply rail with a ground return. Single-ended chips may show a very large offset voltage at their outputs. Also check for a hairline short in the PC card foil traces. Here are several tips that will aid in troubleshooting:

1. Make sure the switches are in the proper position before testing the unit.
2. Very hot IC's usually indicate an internal short.
3. An open resistor may lead you to believe that an IC is defective. Use a substitute device to see if the problem is in the device itself or elsewhere.
4. Shorted input capacitors may bias an IC opamp OFF.
5. Be sure IC's are firmly in their sockets. They can be vibrated loose during shipment.

The following paragraph applies to earlier units equipped with the analog time delay card — MOD2X335:

Signal tracing procedures may also be employed when servicing the time delay portion of the SURROUND CHANNEL(s). A signal at the input, through the filter circuit, the delay chip, and the anti-alias filter will reveal where the signal has stopped. Refer to the schematic for pin identification of the signal flow. The HFE4047 clock associated with the delay chip must be operating properly for the audio signal to pass through the delay chip. An oscilloscope will reveal high level square wave pulses on pins 10 and 11 of the 4047 when this device is operating. If either phase of the clock fails, no audio can pass. We suggest you **NOT REMOVE** the delay chip itself unless you are positive it has failed. This component is very expensive and can be easily destroyed by stray static caused by handling. The BIAS pots near the chips are factory set to each individual chip, and should not be moved unless the IC must be replaced by a new device.

The MATRIX CARD and NOISE REDUCTION CARDS in the MOD V contain many components and IC's that are factory calibrated. The Matrix Card is not intended to be serviced without special test equipment and test fixtures. A defective card may be exchanged with a new one from the factory. We do suggest, though, that the MOD V be returned to the factory for servicing if a failure is verified. An important part of any pre-service call is to make sure that the operator or other theater personnel is fully familiar with the operation of this equipment. Often service calls are

made unnecessarily because the operator was not trained with the correct operation procedures.

MANY IC DEVICES CAN BE DESTROYED BY HANDLING. CMOS logic devices and Bi-FET opamps are very static sensitive. They are safe when plugged into their sockets, but removal can expose the inputs to conduct static electricity from tools, your hands, or other static generating components. **USE PROPER HANDLING PROCEDURES** when removing IC's from their sockets.

This manual is included with each shipment so that you can leave a copy with the theatre owner or operator.

SERVICE ACCESS:

The MOD V contains up to 16 plug-in printed circuit cards, depending on the system configuration. These cards should be removed **ONLY WHEN MAIN POWER HAS BEEN REMOVED**. Plugging in a card with power present can cause a jolt to the input regulators, causing them to fail. It should never be necessary to remove the main "Mother Board" that lies at the rear of the card cage.

To replace LED's in, or otherwise service the front panel, the printed circuit card must be detached from the front panel. First, remove the 50 pin ribbon cable. Then, remove the 8 screws holding it to standoffs mounted on the rear of the front panel. It is **NOT** necessary to remove the knobs on the Fader pots before attempting to release the card. After the screws have been removed, slowly and carefully pull the card back from the front panel so that all and LED's are clear of their holes.

To reassemble the unit, follow the directions in reverse. Before tightening the screws holding the card to the standoffs, make sure the LED's are seated squarely in their front panel holes.

P.C. CARD COMPONENT REPLACEMENT:

All IC's in the MOD V PC cards are socketed and can easily be replaced from the top surface of the boards.

WARNING:

Disconnect the power supply from the AC power line before replacing components to avoid the danger of electrical shock.

If any of the CMOS logic chips are replaced, use reasonable care to avoid damage due to static electricity. If the relative humidity is below 50%, use a grounded workbench and make sure that the PC board is grounded to it. To prevent static damage to a chip, do not touch any of the leads unless you are also touching the workbench, or you are connected to it through a standard high-resistance grounded wrist strap. (Such wrist straps are connected to ground through a 1 megaohm or more resistor, greatly reducing danger to personnel due to electric shock.)

Other components that are soldered in place may be replaced following the instructions covered in this section.

If filter capacitors are to be replaced, fasten them securely to the board using the original factory installation as a model. This will prevent them from breaking loose from vibration in the future.

REPLACEMENT PARTS:

If you have difficulty finding parts for this or any other SMART product, The SMART Technical Support Department stands ready to supply you with the required parts at a fair price. Please contact us at the address on the title page of this manual.

REPLACEMENT OF COMPONENTS ON PRINTED CIRCUIT BOARDS:

It is important to use the correct technique for replacing components mounted on PC boards. Failure to do so will result in possible circuit damage and/or intermittent problems.

The circuit boards used in the MOD V are the double-sided plated-through type. This means that there are traces on both sides of the boards, and that the through-holes contain a metallic plating in order to conduct current through the board. Because of the plated-through holes, solder often creeps 1/16" up into the hole, requiring a sophisticated technique of component removal to prevent serious damage to the board.

COMPONENT REMOVAL:

If the technician has no practical experience with the demanding technique of removing components from double-sided PC boards without board damage, it is wiser to cut each of the leads of the defective component from its body while the leads are still soldered to the board. The component is then discarded, and each lead is heated independently and pulled out of the board with long nose pliers. Each hole may be cleared of solder by using solder wick or by carefully heating with a low-wattage soldering iron and sucking out the remaining solder with a spring-activated desoldering tool. **THIS METHOD IS THE BEST METHOD OF CLEARING A PLATED-THROUGH HOLE OF SOLDER.**

Another technique is:

1. Use a 30 watt soldering iron to melt the solder on the underside (solder side) of the PC board. Do not use a soldering gun or high wattage iron! As soon as the solder is molten, vacuum it away with a spring activated desoldering tool like the Edsyn "Soldapult." Do not overheat the board! Overheating will almost surely damage the board by causing the conductive foil to separate from the board. Use a pair of fine needle-nose pliers to wiggle the lead horizontally until it can be observed to move freely in the hole.

2. Repeat step 1 until each lead to be removed has been cleared of solder and is free to move.

3. Now lift the component out of the holes.

COMPONENT INSTALLATION:

1. Bend the leads of the replacement component until it will fit easily into the appropriate PC board holes. Using a good brand of rosin-core solder, solder each lead to the bottom side of the board with a 30 watt soldering iron. Make sure that the joint is smooth and shiny. If no damage has been done to the plated through hole, soldering the topside pad is not necessary. However, if the removal procedure did not progress smoothly, it would be wise to solder each lead at the topside to avoid potential intermittent problems.