

INSTALLATION AND OPERATION MANUAL

MN520 FOUR CHANNEL MONITOR

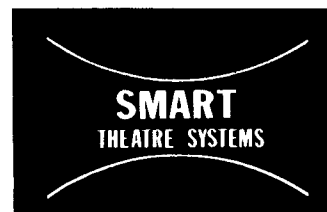

SMART THEATRE SYSTEMS

3856 Green Industrial Way, Atlanta, GA 30341 (404) 452-1820

MN520

FOUR CHANNEL ACTIVE BOOTH MONITOR

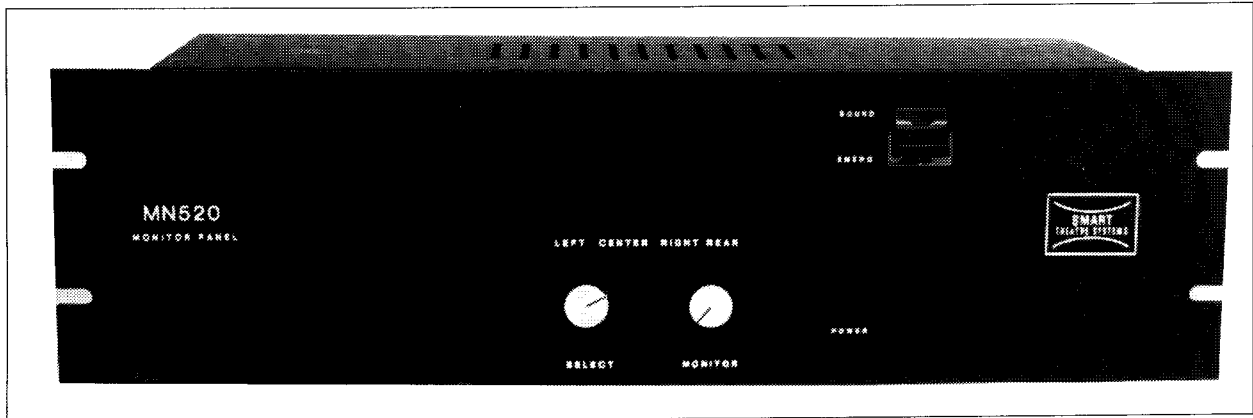

MONITORS PROCESSOR OR POWER AMPLIFIERS

FEATURES

- FOUR CHANNEL LEVEL INDICATORS
- MONITOR EACH AUDIO CHANNEL
- MAY BE USED TO MONITOR POWER AMPLIFIER OUTPUTS OR PROCESSOR
- BUILT-IN AMPLIFIER AND SPEAKER
- QUALITY COMPONENTS
- 120 VAC OR 240 VAC 50/60 HZ
- EMERGENCY AMPLIFIER

The SMART MN520 is a space saving product that contains an active booth monitor system in a rack mounted 5 1/4" package. This product is similar to the famous EX500B model except it does not contain the regulated exciter lamp supply package. Four LED arrays constantly monitor the level from four independent audio channels, while a built-in audio amplifier section powers a quality 5 inch monitor loud-speaker.

A large red screen on the front panel of the MN520 contains calibrated LED arrays that show the operator the volume level from the each channel of the film source. The LED arrays may monitor the output of the Stereo Decoder, or may be used to monitor the outputs of the power amplifiers in the sound system. When properly adjusted, the arrays will measure maximum range of 100% modulation from the film source. These indicators are valuable in helping the operator determine relative loudness in the auditorium.

Each stereo channel may be monitored separately with the front panel monitor selector switch. When the switch is moved to a channel, the booth monitor will reproduce the sound of that channel and the respective LED array will show a BAR of light. Unselected channels will display their volume level with a traveling DOT of light. All front channels may be monitored by selecting the ALL position.

The built-in power amplifier doubles as an emergency amplifier for the center stage speaker. An emergency switch on the front panel turns off the monitor speaker and directs its output to the screen center stage speaker until the main amplifier can be repaired.

MN520 INSTALLATION CRASH COURSE



Here is a quick explanation of the hookup of the MN520 Monitor-Exciter Supply. If you have installed this unit before, then this can be a brief check list. If not, then consider the following as an overview of the installation requirements.

- Using shielded audio cable, hook the sound system preamplifier or decoder outputs to the monitor input terminals for each channel. Ground the shield to the terminals.
- Connect the system main power amplifier center channel OUTPUT TERMINALS to the MN520 terminals marked AMP OUT. Observe the amplifier ground terminal is connected to the terminal of the MN520.
- Hook the stage speaker line to the SPKR terminals of the MN520. Observe phasing with other stage channels.
- Calibrate the PROGRAM LEVEL INDICATORS with the Dolby™ tone test loop using the “tuning wand” through the proper holes in the rear of the chassis.
- Plug the devices you wish to switch on and off by the front panel POWER SWITCH into the CONVENIENCE OUTLETS on the rear of the MN520.

A more complete description of the installation and adjustment of the MN520 Monitor-Exciter Supply is included in this manual.

MN520 INSTALLATION AND SERVICE MANUAL

The SMART MN520 is a space saving product that contains an active booth monitor system in a rack mounted 5¼ inch package. The MN520 is similar to the EX500 model except it does not contain a regulated exciter lamp supply. When installing this product, keep in mind that there are two sections that are independent in their functions. Four LED arrays monitor the level from four independent audio channels, while an audio amplifier section powers the built in 5 inch high fidelity monitor speaker. Refer to the schematic diagram for details on the internal wiring.

VENTILATION. To assure long life and cool operation, it is necessary to assure that there is adequate air flow across the MN520 chassis. Do not rack mount the MN520 directly above heat generating equipment (power amps, other supplies, etc.) without a spacer or vent panel to separate the distance.

PROTECTION. There is a fuse accessible from the rear of the product that protects the circuits. The main AC line fuse is a 1 amp 250 volt 3AG type. Be sure the proper fuse is installed to avoid a possible hazard or service call. Please advise the theater owner or operator as to where spare fuses are stored.

RACK MOUNTING. The MN520 should be mounted in a position in the rack where it is easily accessible to the operator. The monitor FADER control should be conveniently available, and the PROGRAM LED READOUTS are easily visible. We suggest that the unit be mounted in the upper half of the rack space, near the main preamp fader. Use a vent panel above and below the unit for proper air circulation. Four rack mounting screws are furnished with the product.

BOOTH MONITOR AND PROGRAM METER

MONITOR WIRING. Connect a shielded audio cable from each channel of the output of the device being monitored, to the amplifier input terminals on the rear of the MN520. The input terminals are labeled for easy identification. Each input terminal is an unbalanced audio input, and a nearby terminal is shield ground. Connect shielded cable from the source equipment to the other inputs of the MN520 in a similar manner. The inputs are labeled **(L)**eft, **(C)**enter, **(R)**ight, and **(S)**urround. Keep these audio cables away from AC lines or speaker cables when routing your inputs from the sending device (Decoder, Preamp, etc.) to the monitor amplifier. **DO NOT CONNECT THE OUTPUT OF THE CENTER CHANNEL POWER AMPLIFIER TO THE INPUT OF THE MONITOR AMPLIFIER.** Although the monitor amplifier would perform quite well (with proper padding), you will have *no emergency backup* if the main amplifier fails. The booth monitor must have a continuous audio input from the preamplifier in order to function as a backup system.

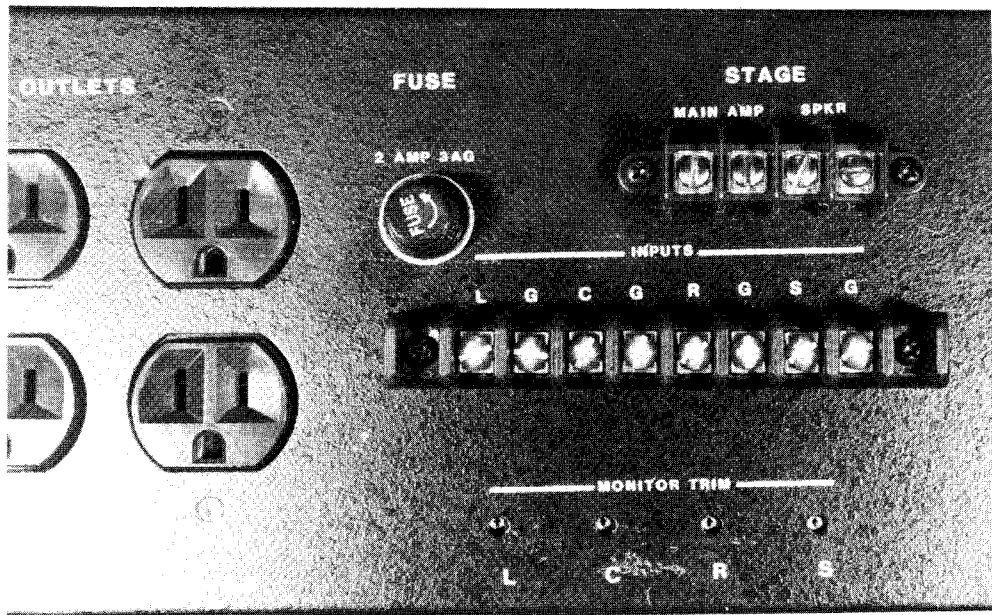

THE MONITOR AND DISPLAY SOUND LEVEL DRIVE CONTROLS, ALONG WITH THE INPUT AND OUTPUT CONNECTIONS FOR THE MN520 ARE ON THE REAR OF THE CHASSIS.

MONITOR OUTPUT. In order to function as a backup system to the main amplifier, the MN520 must receive the output signal from the main power amplifier. This power signal is passed through the front panel SOUND-EMERG(EMERGENCY) switch, which then sends the power signal to the main stage speaker. Wire the output of the sound system main amplifier to the terminals labeled AMP OUT. (This refers to the amplifier output of the main system power amplifier and not the monitor amplifier output.) Wire the STAGE SPEAKER to the terminals labeled SPEAKER. When the front panel switch is in the SOUND position, the main system amplifier will feed the stage speaker directly, and the monitor amplifier will feed the internal monitor speaker. If the operator moves the front panel switch to the EMERG position, the main amplifier is cut off from the stage speaker and the booth monitor feeds the stage speaker. The front panel MONITOR FADER will then control the volume in the auditorium. The internal monitor speaker is disconnected when the EMERG is activated to minimize the load on the small monitor amplifier. Be sure to observe polarity of the center channel speaker when passing through the Emergency switch so that all stage speakers are properly phased for stereo. Only the center channel is switched during emergency. Also note that some power amplifiers *ground* one of the output terminals. Make sure the "hot" output terminal of the amp is not connected to the MN520 ground terminal.

NOTE: The main system power amplifier may have one output terminal grounded. Make sure that the grounded chassis terminal goes to the ground terminal of the MN520. If you make a mistake on hookup, you could blow out the amplifier.

MN520 Monitor

PROGRAM LEVEL INDICATORS. A large red screen on the front panel of the MN520 contains LED arrays that show the operator the volume level coming from the film for each channel. When properly calibrated, each array will register maximum range with 100% modulation from the film source. Trailers and short subjects may register a high level, whereas feature films may have a moderate output level. The LED indicator arrays are valuable in helping the operator determine relative loudness in the auditorium. The soft illumination is ideal for a normally lit projection booth.

CALIBRATION. There are small holes in the rear of the chassis below the monitor amplifier INPUT TERMINALS. These holes access the meter calibrate controls for each channel and may be reached with the "tuning wand" supplied with the MN520. Using the flat blade end of the wand, find the slot in the internal control. With the Decoder MASTER FADER in the normal operating position, and a Dolby™ Reference tone running on the selected projector, rotate the control clockwise for an increase in the LED array height. Adjust the pot until the bottom 5 LED's of the array are lit while playing the 50% modulation reference test loop. When the soundtrack reaches 100% modulation on a feature film all of the 10 LED's will be lit. This setting will indicate the true recorded level on the soundtrack. Trailers and short subjects are usually recorded louder and may register 100% most of the time. The calibrate controls also affect the audio drive to the monitor amplifier. As you increase the trim control to the LED arrays, more audio is fed to the monitor amplifier. Use the test loop furnished with the SMART SR300 or SR135 decoders for the 50% modulation reference, or order one separately.

Here is the procedure that works with most stereo decoders:

- Short the LEFT Solar cell input to neutral (or ground if the input is unbalanced). Set the level of the left channel program meter.
- Remove the short from the left channel and place a short on the RIGHT solar cell input. Set the right channel of the program indicator for 50% modulation.
- Leave the short *in place* and set the level of the surround channel on the program meter.
- Remove the short across the solar cell and adjust the center channel for 50% modulation.

The reason this procedure is necessary is because the SVA matrix in the Stereo Decoder detects in-phase information as center channel information and out-of-phase information as surround material. The matrix also controls the left and right channels by reacting to information that is exclusively on those channels.

INSTALLATION MANUAL

USING THE MN520 WITH SMART EQUIPMENT. The latest generation of Stereo Decoders (SR300 & SR135), and preamps (SXL735) offer a DIRECT OUTPUT terminal on the rear barrier strip to drive other system components with a constant level. The MAIN FADER on these products affects only the main output terminals, and not the DIRECT OUTPUT. You may wish to use the direct output of a stereo decoder to feed the CENTER CHANNEL monitor input of the MN520 and the main output terminals (RIGHT, LEFT and SURROUND) to feed the other monitor inputs. The operator can therefore adjust his MASTER FADER on the stereo decoder to suit the house level requirements without changing the calibration of the CENTER CHANNEL monitor level.

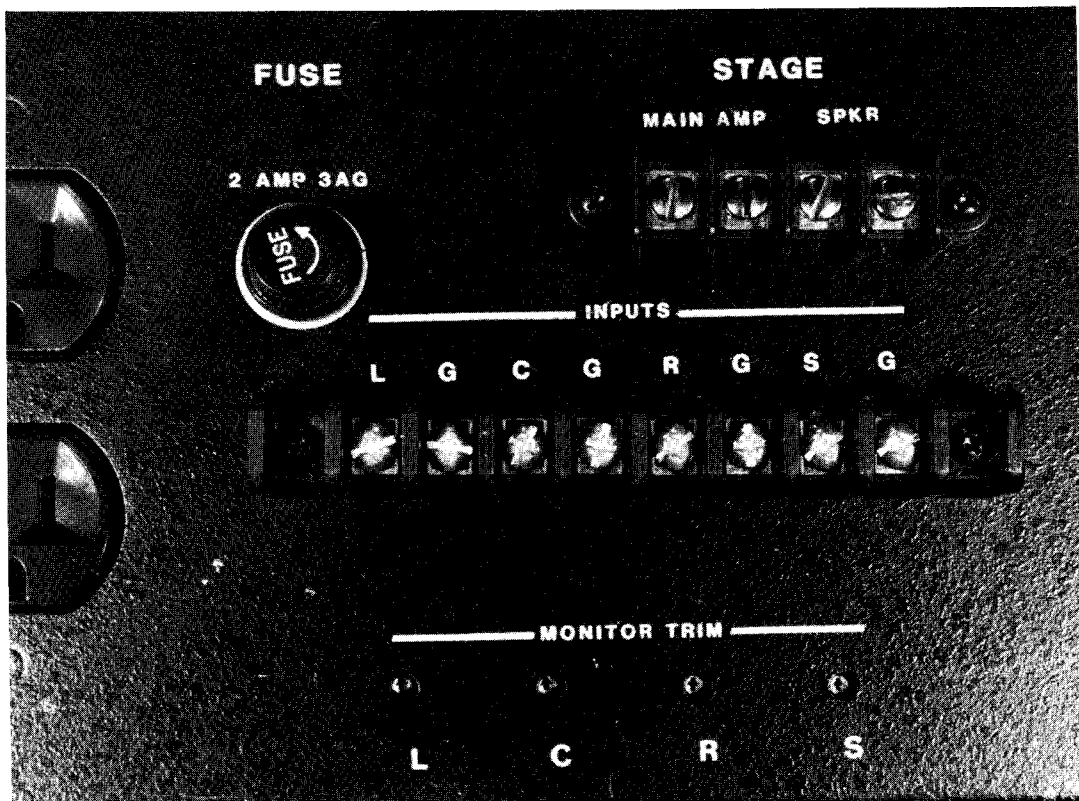

MONITOR AND METER TRIM CONTROLS

AC CONVENIENCE OUTLETS. There are six duplex outlets on the rear of the MN520 chassis that are switched by the front panel power switch. This array of outlets IS NOT FUSED by the MN520. Each piece of equipment plugged into the convenience outlets must be individually fused for protection. The front panel power switch can be used to turn the whole sound system on and off. Be sure that the total current draw through the outlets does not exceed 12 amperes. This is the limitation of the MN520 power cord and switch contacts. Another advantage of using the convenience outlets is that it provides a common ground point in the sound system for the AC green third wire OF EACH PIECE OF EQUIPMENT.

SERVICE

MONITOR AMPLIFIER. The printed circuit card for the monitor amplifier contains the bridge diodes for full wave rectification, and filter capacitor to power the LM384 5 watt integrated circuit power amplifier, along with the supply voltages necessary for the LED display board. The amplifier card plugs into the display board and can be separated by removing the front panel that holds the display board captive. The amplifier chip is soldered to the board in order to properly heat sink the IC to the foil side of the board. A second heat sink is cemented to the top of the IC case. Soldering the chip to the PC board is one of the very few exceptions in SMART equipment where an IC is not socketed. Operating voltage for the amplifier is approximately 21 volts DC. This allows a safety margin for high AC line voltages that could damage the amplifier chip if higher DC voltage were used. The display board has on-board regulators for proper operation.

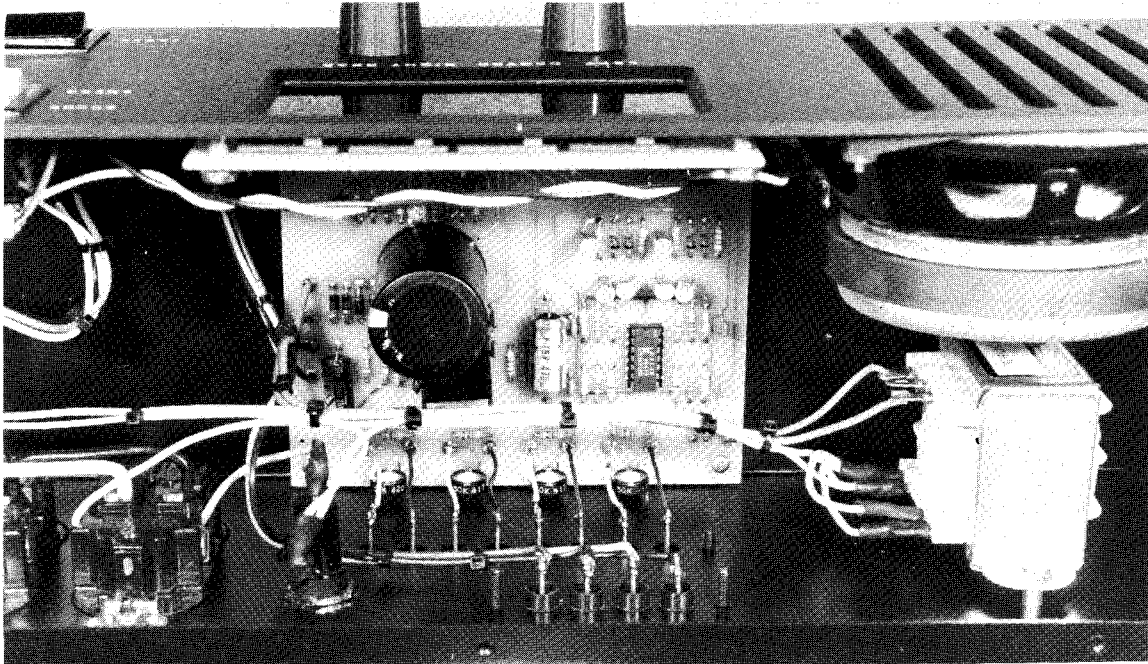

PRINTED CIRCUIT BOARDS IN THE MN520

The entire amplifier card may be removed for replacement by disconnecting the transformer power leads, the audio input leads, and the output leads. The easiest way to remove a bad IC chip is to cut each IC lead on top of the board with cutter pliers, and unsolder each pin from the bottom of the card. Refer to the schematic diagram and parts list for circuit details.

The installer should make the owner or operator aware of the proper operation and features of the SMART MN520 to avoid an unnecessary service call. Be sure the theatre is equipped with spare fuses for emergency use. Also leave a copy of the OPERATING INSTRUCTIONS that are included in this manual.

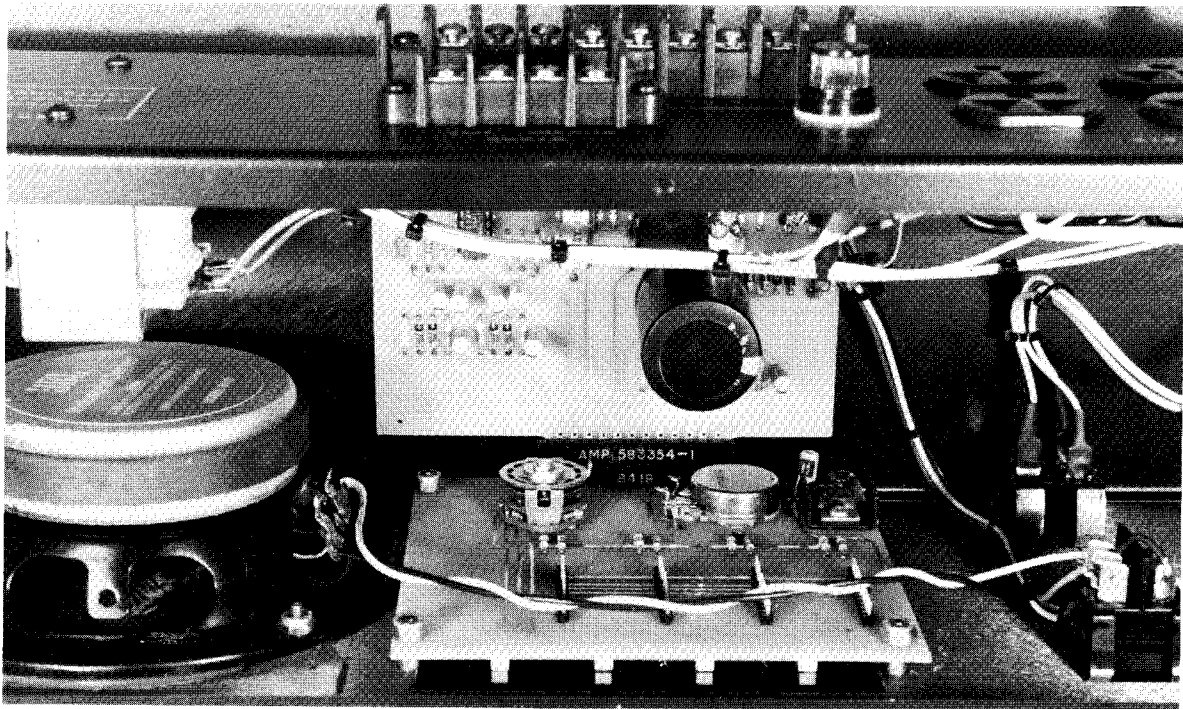

THE MONITOR AMPLIFIER BOARD PLUGS INTO THE LED DISPLAY BOARD. THE FRONT PANEL MAY BE REMOVED TO SERVICE THE MN520 BY REMOVING THE PANEL NUTS (4) ON EACH OUTSIDE EDGE OF THE CHASSIS.

SMART THEATRE SYSTEMS maintains a full service department for repair of products, and a Technical Support department to assist with technical questions. We may be reached during normal business hours at 1-(800) 45-SMART or (404) 452-1820.



MODIFYING THE MN520 TO MONITOR AMPLIFIER OUTPUTS

In certain cases it may be desirable to monitor the outputs of the stereo system power amplifiers instead of the output of the stereo processor. This may be done with a simple change inside the MN520 chassis. The chassis top cover must be removed and changes made before installation into the equipment rack.

The MN520 is shipped with its monitor and level display input sensitivity set for a line level input of 0 dB. The sensitivity is adjustable with the four input level controls accessible through the rear of the chassis. Hooking a power amplifier output to the MN520 inputs would severely overdrive the monitor inputs and possibly burn up the input controls because they would be very close to their minimum setting. The recent version of the MN520 has an amplifier input audio pad that lowers the sensitivity of the unit so that the controls have full adjustment range and will not overdrive the input stages of the product. **The pads are ONLY installed on the LEFT, RIGHT, and SURROUND channels of the MN520 inputs.** It is highly recommended that you **NOT** feed the center channel of the MN520 from the power amplifier output because the EMERGENCY feature will not work if the center channel power amplifier fails.

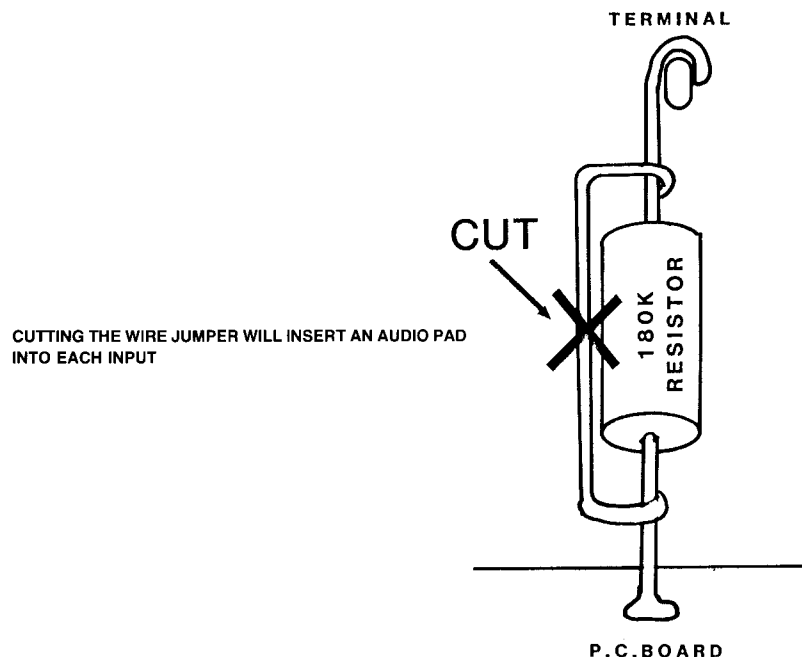

Locate the input barrier strip terminals for the audio inputs *inside the chassis*. There are three 180K resistors that connect to the barrier strips on the LEFT, RIGHT, and SURROUND inputs and extend to the printed circuit board. Each resistor has a wire jumper around the resistor element that effectively shorts the resistor out of the circuit. By cutting the jumper the resistor *is inserted as a series resistance* into the audio path, forming a pad with the shunt resistance of the input control for each channel. **DO NOT CUT** the GROUND wire that connects the terminal to the board.

OPERATING INSTRUCTIONS

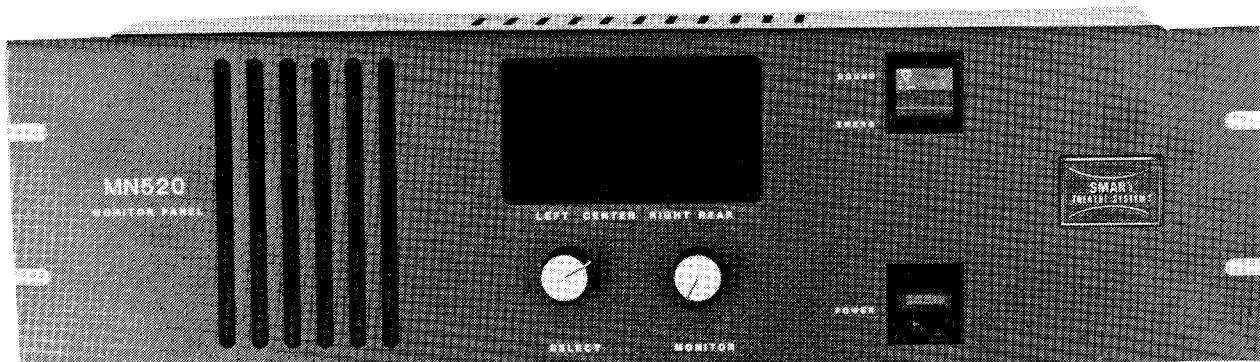

POWER SWITCH. Turns the sound system ON and OFF. The other components of the system are plugged into the convenience outlets on the rear of the MN520 and will be controlled by the master power switch.

SOUND-EMERG SWITCH. The main center channel power amplifier output passes through the SOUND-EMERG switch to the stage loudspeaker system. If the main amplifier fails during a show, this switch substitutes the built in monitor amplifier as a backup. The MONITOR FADER must be set for sufficient loudness in the auditorium. When the switch is activated, the booth monitor will be disconnected.

MONITOR CONTROL. The front panel monitor FADER sets the listening level of the booth monitor when the SOUND-EMERG switch is in its normal SOUND position. When the switch is in the EMERG position, no sound will be heard from the booth monitor speaker. The monitor control now sets the loudness of the stage speaker.

PROGRAM LEVEL INDICATORS. Indicates the level at which the soundtrack was recorded. These indicators may be useful in determining how loud the sound is in the auditorium.

SELECT SWITCH. Allows the operator to “scan” the channels individually to monitor each source of a multi-channel soundtrack. When the switch is on the monitored channel, the display turns to a solid bar while the other channels indicate the level with a dot. The normal operating position for this switch is on the center channel.

PROTECTION. There is a main power fuse on the rear of the chassis that protect the internal circuits. The fuse should be replaced with only the proper size. The main fuse is a 1 AMP 3AG type.

For an expanded explanation of each of the circuits and features, see the appropriate section of the installation and service manual.

MN520 Monitor

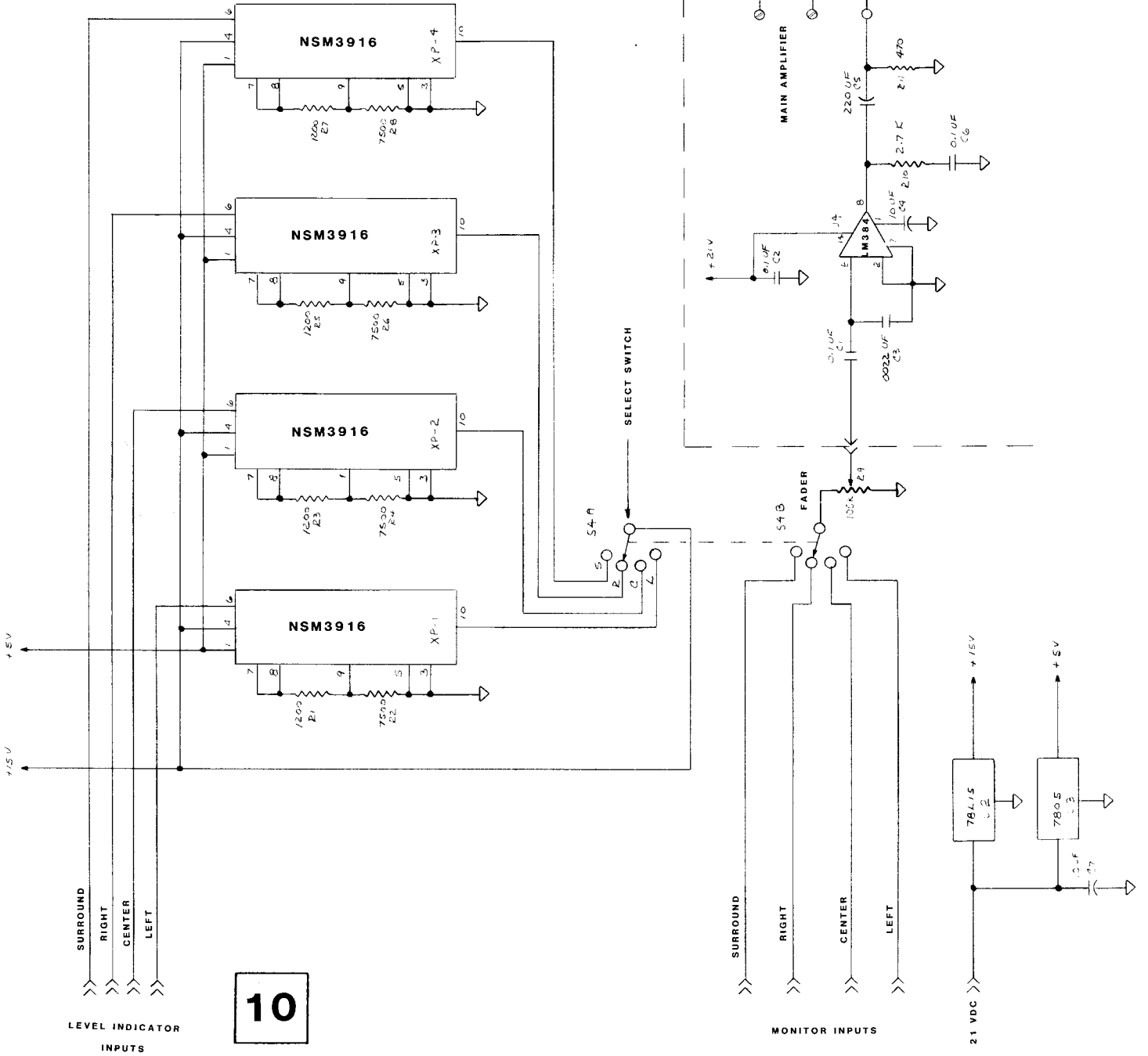

10

MN520 4 CHANNEL MONITOR

APPROVED BY: _____
 SCALE: _____
 DATE: _____
 DRAWN BY: _____
 REVISED: _____

LED ARRAY MONITOR BOARD

SHEET # 1 OF 3

DRAWING NUMBER
 0520A300

MN520 Monitor

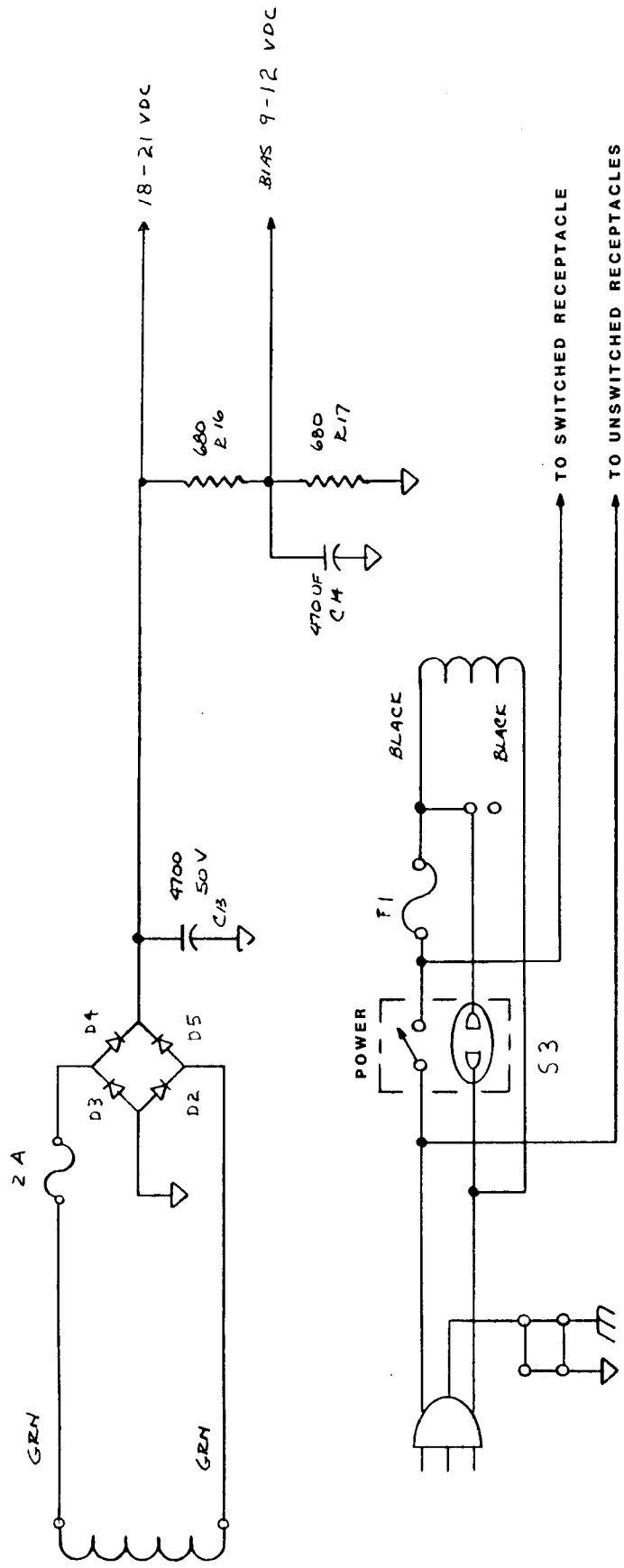

MN520 4 CHANNEL MONITOR	
SCALE:	APPROVED BY:
DATE:	DRAWN BY:
EXCITER SUPPLY AMP SUPPLY	
DRAWING NUMBER 0520A301	
SHEET #2 OF 3	

MN520 Monitor

MN520 4 CHANNEL MONITOR

AUDIO DISPLAY DRIVERS

SHEET #3 OF 3

SCALE: _____ APPROVED BY: _____
 DATE: _____ DRAWN BY: _____
 REVISED: _____

17225 PRINTED ON 100% RECYCLED PAPER

12

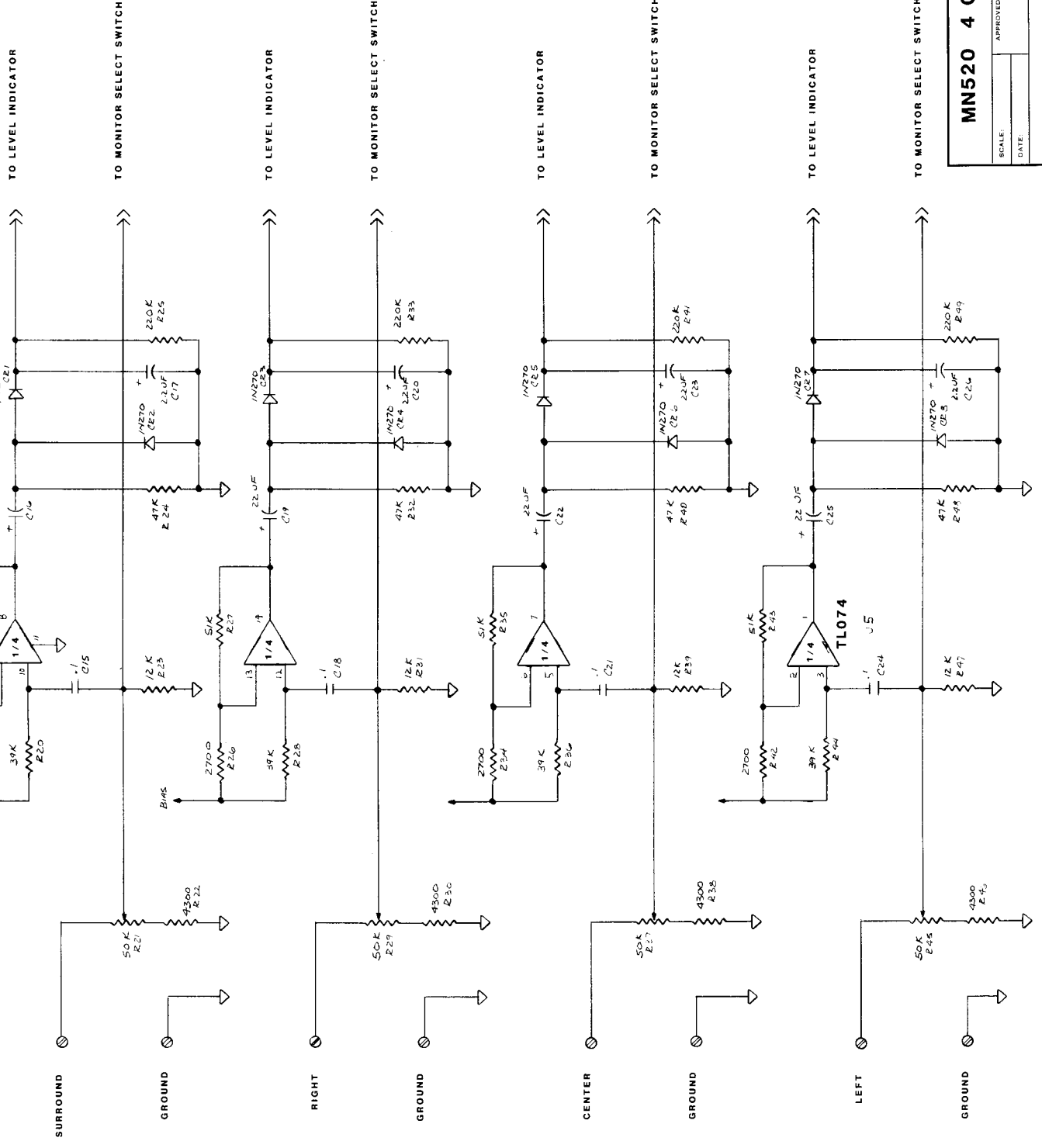

PARTS LIST MN520

R1	RESISTOR	1200	1/4 WATT 5%	C16	CAPACITOR	22 UF	16 V ELECTRO
R2	RESISTOR	7500	1/4 WATT 5%	C17	CAPACITOR	2.2 UF	16 V ELECTRO
R3	RESISTOR	1200	1/4 WATT 5%	C18	CAPACITOR	0.1 UF	50 V CERAMIC
R4	RESISTOR	7500	1/4 WATT 5%	C19	CAPACITOR	22 UF	16 V ELECTRO
R5	RESISTOR	1200	1/4 WATT 5%	C20	CAPACITOR	2.2 UF	16 V ELECTRO
R6	RESISTOR	7500	1/4 WATT 5%	C21	CAPACITOR	0.1 UF	50 V CERAMIC
R7	RESISTOR	1200	1/4 WATT 5%	C22	CAPACITOR	22 UF	16 V ELECTRO
R8	RESISTOR	7500	1/4 WATT 5%	C23	CAPACITOR	2.2 UF	16 V ELECTRO
R9	POT, TRIM	100K	P.C. MOUNT	C24	CAPACITOR	0.1 UF	50 V CERAMIC
R10	RESISTOR	2.7K	1/4 WATT 5%	C25	CAPACITOR	22 UF	16 V ELECTRO
R11	RESISTOR	470	1/4 WATT 5%	C26	CAPACITOR	2.2 UF	16 V ELECTRO
R16	RESISTOR	680	1/4 WATT 5%	D2	DIODE	1 AMP	50V RECTIFIER
R17	RESISTOR	680	1/4 WATT 5%	D3	DIODE	1 AMP	50V RECTIFIER
R18	RESISTOR	2700	1/4 WATT 5%	D4	DIODE	1 AMP	50V RECTIFIER
R19	RESISTOR	51K	1/4 WATT 5%	D5	DIODE	1 AMP	50V RECTIFIER
R20	RESISTOR	39K	1/4 WATT 5%	S1	SWITCH	DPDT	PANEL
R21	POT, TRIM	50K	P.C. MOUNT	S3	SWITCH	SPDT	PANEL, NEON
R22	RESISTOR	4300	1/4 WATT 5%	S4	SWITCH	4P3T	PANEL, ROTARY
R23	RESISTOR	12K	1/4 WATT 5%	S5	SWITCH	DPDT	PANEL
R24	RESISTOR	47K	1/4 WATT 5%	SPK1	SPEAKER	8 OHM	PANEL, 5 INCH
R25	RESISTOR	220K	1/4 WATT 5%	TI	TRANSFORMR	241436	POWER 117/220V
R26	RESISTOR	2700	1/4 WATT 5%	U2	I C	.5 AMP	78L15 REGULATOR
R27	RESISTOR	51K	1/4 WATT 5%	U3	I C	1 AMP	7805 REGULATOR
R28	RESISTOR	39K	1/4 WATT 5%	U4	AMPLIFIER	5 WATT	LM384 W/SINK
R29	POT, TRIM	50K	P.C. MOUNT	U5	QUAD OPAMP	TL074	14 PIN DIP PACK
R30	RESISTOR	4300	1/4 WATT 5%	CR1	DIODE	SM SIG	GERMANIUM GLASS
R31	RESISTOR	12K	1/4 WATT 5%	CR2	DIODE	SM SIG	GERMANIUM GLASS
R32	RESISTOR	47K	1/4 WATT 5%	CR3	DIODE	SM SIG	GERMANIUM GLASS
R33	RESISTOR	220K	1/4 WATT 5%	CR4	DIODE	SM SIG	GERMANIUM GLASS
R34	RESISTOR	2700	1/4 WATT 5%	CR5	DIODE	SM SIG	GERMANIUM GLASS
R35	RESISTOR	51K	1/4 WATT 5%	CR6	DIODE	SM SIG	GERMANIUM GLASS
R36	RESISTOR	39K	1/4 WATT 5%	CR7	DIODE	SM SIG	GERMANIUM GLASS
R37	POT, TRIM	50K	P.C. MOUNT	CR8	DIODE	SM SIG	GERMANIUM GLASS
R38	RESISTOR	4300	1/4 WATT 5%	XP-1	DISPLAY	LEDS	NSM3916 ARRAY
R39	RESISTOR	12K	1/4 WATT 5%	XP-2	DISPLAY	LEDS	NSM3916 ARRAY
R40	RESISTOR	47K	1/4 WATT 5%	XP-3	DISPLAY	LEDS	NSM3916 ARRAY
R41	RESISTOR	220K	1/4 WATT 5%	XP-4	DISPLAY	LEDS	NSM3916 ARRAY
R42	RESISTOR	2700	1/4 WATT 5%				
R43	RESISTOR	51K	1/4 WATT 5%				
R44	RESISTOR	39K	1/4 WATT 5%				
R45	POT, TRIM	50K	P.C. MOUNT				
R46	RESISTOR	4300	1/4 WATT 5%				
R47	RESISTOR	12K	1/4 WATT 5%				
R48	RESISTOR	47K	1/4 WATT 5%				
R49	RESISTOR	220K	1/4 WATT 5%				
C1	CAPACITOR	0.1 MF	50 VOLT CERAMIC				
C2	CAPACITOR	0.1 MF	50 VOLT CERAMIC				
C3	CAPACITOR	.0022	50 VOLT POLY				
C4	CAPACITOR	10 UF	16 V ELECTRO				
C5	CAPACITOR	220 UF	16 V ELECTRO				
C6	CAPACITOR	0.1 UF	50 V CERAMIC				
C7	CAPACITOR	10 UF	16 V ELECTRO				
C13	CAPACITOR	4700UF	50 V ELECTRO				
C14	CAPACITOR	470 UF	16 V ELECTRO				
C15	CAPACITOR	0.1 UF	50 V CERAMIC				