



**CAT. NO. 701**

**DIGITAL SOUNDHEAD**

**Installation Instructions**

ISSUE 03

Part No. 91478

**NOTE:** For complete system installation please refer to the Model CP500 or Model DA20 Installation Manual.

# INSTALLATION INSTRUCTIONS

## FOR

### CAT. NO. 701 DIGITAL SOUNDHEAD

**Dolby Laboratories Incorporated**

U.S.A. 100 Potrero Avenue, San Francisco, CA 94103  
Tel: 415-558-0200; Fax: 415-863-1373

U.K. Wootton Bassett, Wiltshire SN4 8QJ  
Tel: (44) 1793-842100; Fax: (44) 1793-842101

[www.dolby.com](http://www.dolby.com)

**DISCLAIMER OF WARRANTIES:** Equipment manufactured by Dolby Laboratories is warranted against defects in materials and workmanship for a period of one year from the date of purchase. **There are no other express or implied warranties and no warranty of merchantability or fitness for a particular purpose.**

**LIMITATION OF LIABILITY:** It is understood and agreed that Dolby Laboratories' liability whether in contract, in tort, under any warranty, in negligence or otherwise shall not exceed the cost of repair or replacement of the defective components and under no circumstances shall Dolby Laboratories be liable for incidental, special, direct, indirect or consequential damages (including but not limited to damage to software or recorded audio or visual material), or loss of use, revenue or profit even if Dolby Laboratories or its agents have been advised, orally or in writing, of the possibility of such damages.

Dolby and the double-D symbol are registered trademarks of Dolby Laboratories.

©1997 Dolby Laboratories

ISSUE 3  
S97/11596/11744  
Dolby Part No. 91478

## SECTION 1 POWER REQUIREMENTS

---

### Power Requirements

The Cat. No. 701 Digital Soundhead contains an internal power supply and is intended for operation at nominal 120Vac or 240 Vac input and nominal 5Vdc output. The switching power supply used in the Cat. No. 701 may be used with mains voltages in the range 85-265 Vac, 50-60 Hz without adjustment for input voltage.

#### **FUSE—T 400mA 5mm x 20mm Time Lag**

The fuse may be inspected or replaced by removing the power cord from the unit and opening the hinged cover of the power entry module. The fuse holder can then be removed.

### Regulatory Notices

#### **FCC**

This equipment has been tested and found to comply with the limits for a Class A digital device, pursuant to part 15 of the FCC Rules. These limits are designed to provide reasonable protection against harmful interference when the equipment is operated in a commercial environment. This equipment generates, uses, and can radiate radio frequency energy and, if not installed and used in accordance with this instruction manual, may cause harmful interference to radio communications. Operation of this equipment in a residential area is likely to cause harmful interference in which case the user will be required to correct the interference at his or her own expense.

#### **UL**

Troubleshooting must be performed by trained technicians. Do not attempt to service the unit unless you are qualified to do so. A power cord for connecting to 120 Vac mains is supplied with units shipped to U.S. destinations.

**WARNING:** Check that the correct fuse has been installed. To reduce the risk of fire, replace the fuse only with the same type and rating. Do not use a ground-lifting adapter and never cut the ground pin on the three-prong power plug.

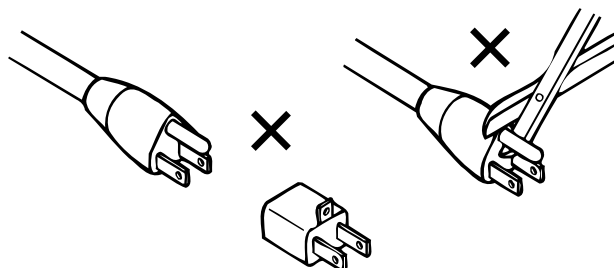

**UK**

Connections for United Kingdom.

**WARNING: THIS APPARATUS MUST BE EARTHED.**

As the colours of the cores in the mains lead may not correspond with the coloured markings identifying the terminals in your plug, proceed as follows:

- The core which is coloured green and yellow must be connected to the terminal in the plug which is marked with the letter **E** or by the earth symbol  $\perp$ , or coloured green or green and yellow.
- The core which is coloured blue must be connected to the terminal which is marked with the letter **N** or coloured black.
- The core which is coloured brown must be connected to the terminal which is marked with the letter **L** or coloured red.

**IEC NOTICES**

LED Light  
**DO NOT STARE INTO BEAM**  
CLASS 2 LED Product Per EN 60825-1:1996 1mW at 650-680 nm



Faisceau de LED  
**Ne pas rester dans le faisceau**  
LED Classe 2 selon EN 60825-1:1996 1 mW à 650-580 nm



LED Lichtquelle  
**Nicht in den Lichtstrahl blicken**  
LED der Kategorie 2 entspr. EN 60825-1:1996 1 mW bei 650-680 nm



L'indicatore del LED  
**Non guardare fissamente il raggio**  
Prodotto LED classe 2 secondo al EN 60825-1: 1996 1 mW a 650-680 nm



La luz LED  
**No mire fijamente al rayo de luz**  
Producto LED clase 2 según el estándar EN 60825-1: 1996 1 mW a 650-680 nm



LED ljus  
**Undvik att titta direkt in i laser strålen**  
Klass 2 LED produkt per EN 60825-1:1996 1 mW wid 650-680 nm



LED belichting  
**Kijk niet in de lichtstraal**  
Klasse 2 LED product volgens EN60825-1:1996 1 mW bij 650-680 nm



**IMPORTANT SAFETY NOTICE**

This unit complies with the safety standard IEC65. To ensure safe operation and to guard against potential shock hazard or risk of fire, the following **must** be observed:

- If the unit has a **voltage selector**, ensure that it is set to the correct mains voltage for your **supply**. If there is no voltage selector, ensure that your supply is in the correct range for the input requirement of the unit.
- Ensure **fuses** fitted are the **correct rating and type** as marked on the unit.
- The unit **must be earthed** by connecting to a correctly wired and **earthed** power outlet.
- The **power cord** supplied with this unit must be wired as follows:  
Live—Brown    Neutral—Blue    Earth—Green/Yellow

GB

**IMPORTANT – NOTE DE SECURITE**

Ce materiel est conforme à la norme IEC65. Pour vous assurer d'un fonctionnement sans danger et de prévenir tout choc électrique ou tout risque d'incendie, veuillez à observer les recommandations suivantes.

- Le selecteur de tension doit être placé sur la valeur correspondante à votre alimentation réseau.
- Les fusibles doivent correspondre à la valeur indiquée sur le materiel.
- Le materiel doit être correctement relié à la terre.
- Le cordon secteur livré avec le materiel doit être câblé de la manière suivante:  
Phase—Brun    Neutre—Bleu    Terre—Vert/Jaune

F

**WICHTIGER SICHERHEITSHINWEIS**

Dieses Gerät entspricht der Sicherheitsnorm IEC65. Für das sichere Funktionieren des Gerätes und zur Unfallverhütung (elektrischer Schlag, Feuer) sind die folgenden Regeln unbedingt einzuhalten:

- Der Spannungswähler muß auf Ihre Netzspannung eingestellt sein.
- Die Sicherungen müssen in Type und Stromwert mit den Angaben auf dem Gerät übereinstimmen.
- Die Erdung des Gerätes muß über eine geerdete Steckdose gewährleistet sein.
- Das mitgelieferte Netzkabel muß wie folgt verdrahtet werden:  
Phase—braun    Nulleiter—blau    Erde—grün/gelb

D

**NORME DI SICUREZZA – IMPORTANTE**

Questa apparecchiatura è stata costruita in accordo alle norme di sicurezza IEC 65. Per una perfetta sicurezza ed al fine di evitare eventuali rischi di scossa elettrica o d'incendio vanno osservate le seguenti misure di sicurezza:

- Assicurarsi che il selettore di cambio tensione sia posizionato sul valore corretto.
- Assicurarsi che la portata ed il tipo di fusibili siano quelli prescritti dalla casa costruttrice.
- L'apparecchiatura deve avere un collegamento di messa a terra ben eseguito; anche la connessione rete deve avere un collegamento a terra.
- Il cavo di alimentazione a corredo dell'apparecchiatura deve essere collegato come segue:  
Filo tensione—Marrone    Neutro—Blu    Massa—Verde/Giallo

I

**AVISO IMPORTANTE DE SEGURIDAD**

Esta unidad cumple con la norma de seguridad IEC65. Para asegurarse un funcionamiento seguro y prevenir cualquier posible peligro de descarga o riesgo de incendio, se han de observar las siguientes precauciones:

- Asegúrese que el selector de tensión esté ajustado a la tensión correcta para su alimentación.
- Asegúrese que los fusibles colocados son del tipo y valor correctos, tal como se marca en la unidad.
- La unidad debe ser puesta a tierra, conectándola a un conector de red correctamente cableado y puesto a tierra.
- El cable de red suministrado con esta unidad, debe ser cableado como sigue:  
Vivo—Marrón    Neutro—Azul    Tierra—Verde/Amarillo

E

**VIKTIGA SÄKERHETSÅTGÄRDER!**

Denna enhet uppfyller säkerhetsstandard IEC65. För att garantera säkerheten och gardera mot eventuell elchock eller brandrisk, måste följande observeras:

- Kontrollera att spänningsväljaren är inställd på korrekt nätspänning.
- Kontrollera att säkringarna är av rätt typ och för rätt strömstyrka så som anvisningarna på enheten föreskriver.
- Enheten måste vara jordad genom anslutning till ett korrekt kopplat och jordat el-uttag.
- El-sladden som medföljer denna enhet måste kopplas enligt följande:  
Fas—Brun    Neutral—Blå    Jord—Grön/Gul

S

**BELANGRIJK VEILIGHEIDS-VOORSCHRIFT:**

Deze unit voldoet aan de IEC65 veiligheids-standaards. Voor een veilig gebruik en om het gevaar van elektrische schokken en het risico van brand te vermijden, dienen de volgende regels in acht te worden genomen:

- Controleer of de spanningscarroussel op het juiste Voltage staat.
- Gebruik alleen zekeringen van de aangegeven typen en waarden.
- Aansluiting van de unit alleen aan een geaarde wandcontactdoos.
- De netkabel die met de unit wordt geleverd, moet als volgt worden aangesloten:  
Fase—Bruin    Nul—Blauw    Aarde—Groen/Geel

NL

## SECTION 2

### INITIAL SETUP AND INSTALLATION

---

## 2.1 Mounting the Digital Soundhead

### Adapter Plates

The Cat. No. 701 Digital Soundhead casting has bolt patterns for several common projector types, and may be mounted to these projectors without an adapter plate:

SIMPLEX 35/70 and XL35  
 CENTURY JJ with 2" bolt adapter  
 CENTURY 35MM-A  
 CHRISTIE P35  
 BALLANTYNE PR0 35

Adapter kits are available for the following projector types.

CINEMECCANICA	V8 / V5 Order Cat. No. 690 Adapter Kit (plate Part No. 67185) needed for re-installing the reel arm to the top of the digital reader.
NORELCO	AAII / DP70 Order Cat. No. 695 Adapter Kit (plate Part No. 67079)
KINOTON	DP75, FP20, FP30 Order Cat. No. 696 Adapter Kit (plate Part No. 67139)

Additional plates may become available. Consult Dolby Laboratories for availability.

Mounting the soundhead on a projector is accomplished by selecting the appropriate adapter plates (if needed), attaching the plates to the soundhead casting, then bolting the plate to the projector and the reel arm or platter guide roller assembly. Lateral positioning is verified by threading a piece of film through the Digital Soundhead and the projector, and verifying equal tension on each edge.

### Installation

While the Digital Soundhead is rugged and reliable, it has been designed and built to precision optical and mechanical tolerances. Handle the unit very carefully.

1. Remove the package of parts from the top of the shipping box.
2. Pull out the inner box containing the Digital Soundhead, and slide it out of the surrounding foam. Place the digital soundhead on a table or bench top, with mounting base down. The mounting base is the surface with thirteen mounting holes. **Figure 2.1** shows how the mounting holes correspond to bolt patterns for various projectors. This diagram shows the hole pattern as viewed from the top, inside the housing.

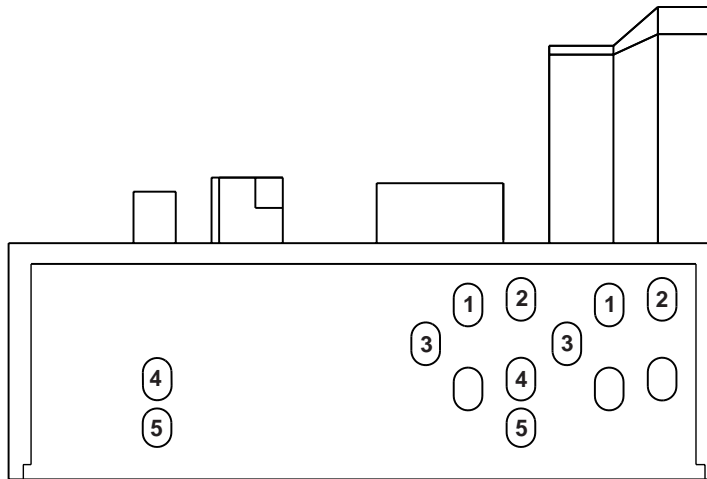

VIEW FROM INSIDE OF READER LOOKING DOWN

- 1 CENTURY JJ WITH 50.8 MM (2 INCH) BOLT PATTERN REEL ARM ADAPTER  
SIMPLEX 35
- 2 CHRISTIE  
CENTURY 35
- 3 SIMPLEX 35 - 70
- 4 CINEMECCANICA V4, V5, V8 (35mm), V9
- 5 CINEMECCANICA V8 (70mm)

Figure 2.1 Mounting Hole Bolt Pattern

3. Remove the six screws which hold the back cover / power supply assembly onto the Digital Soundhead. Carefully remove the LED connector. Put the assembly in a safe place.
4. Remove the upper reel arm or guide rollers from the projector on which the Digital Soundhead is to be mounted.
5. If an adapter kit is necessary, mount the adapter plate to the top of the projector. In the case of the Cat. No. 690 adapter kit, the reader attaches to the projector and the adapter plate attaches to the top of the reader.
6. Mount the Digital Soundhead to the projector body (or adapter plate) matching the appropriate set of bolt holes for the projector type.

**NOTE:** When two Cat. No. 701 Digital Soundheads are mounted for use in a two-projector installation, care must be taken to ensure that the film path lengths between the Digital Soundhead and the picture gates in the two projectors are identical. The soundhead delay setting in the CP500 or DA20 is adjusted for correct synchronization of sound and picture during installation. Since only one adjustment is provided, both projectors must have the same film path length from the Digital Soundhead to the picture gate.

7. Reattach the upper reel arm or guide rollers to the Digital Soundhead, using an adapter plate if necessary.
8. Thread film through the Digital Soundhead and first few rollers of the projector and adjust the placement of the Digital Soundhead such that there is equal tension on each edge of the film, then firmly tighten the mounting bolts.

Set film path so that top and bottom tension arm rollers **A** are approximately 5 MM (1/4 inch) apart. Use the white painted semi-circles **B** for angular alignment of tension arms **C**. Make sure that the rollers do not touch.

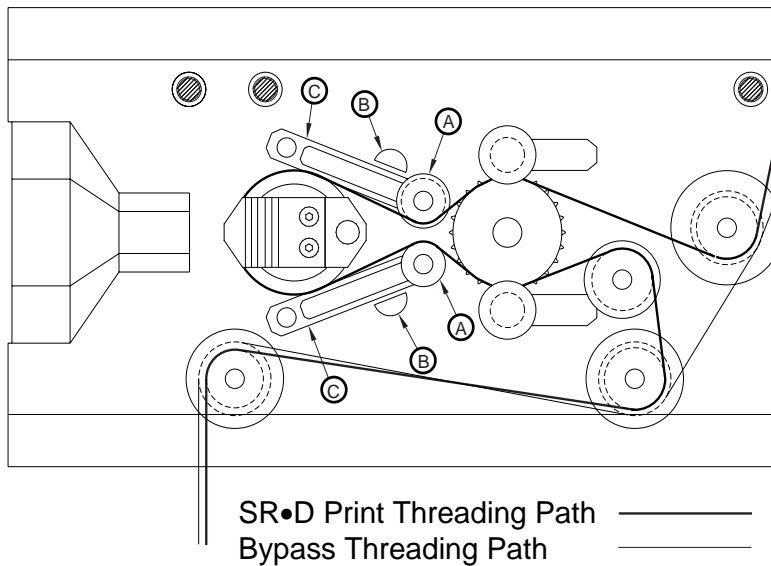

9. If desired, route appropriate conduit from the audio rack where the CP500 or DA20 is to be installed, terminating the conduit at the end of the Digital Soundhead. The soundhead has an unthreaded 27 mm diameter hole in a 2 mm plate to accept 3/4" (USA) conduit fittings or 25 mm (Europe) conduit adapters. Be sure to follow all local electrical codes.
10. Remove the shipping collar using the supplied Allen wrench, and install the Digital Soundhead flywheel, which is packed separately for shipping (see **Figure 2.2**).
11. Replace the cover / power supply assembly.
12. Route the video cable to the soundhead (see Section 2.2).

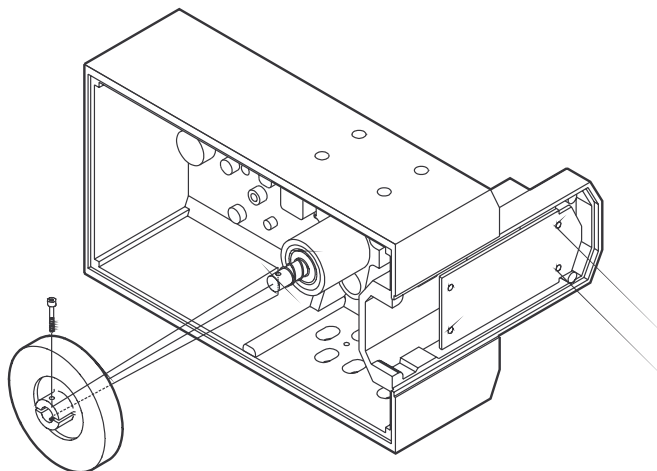
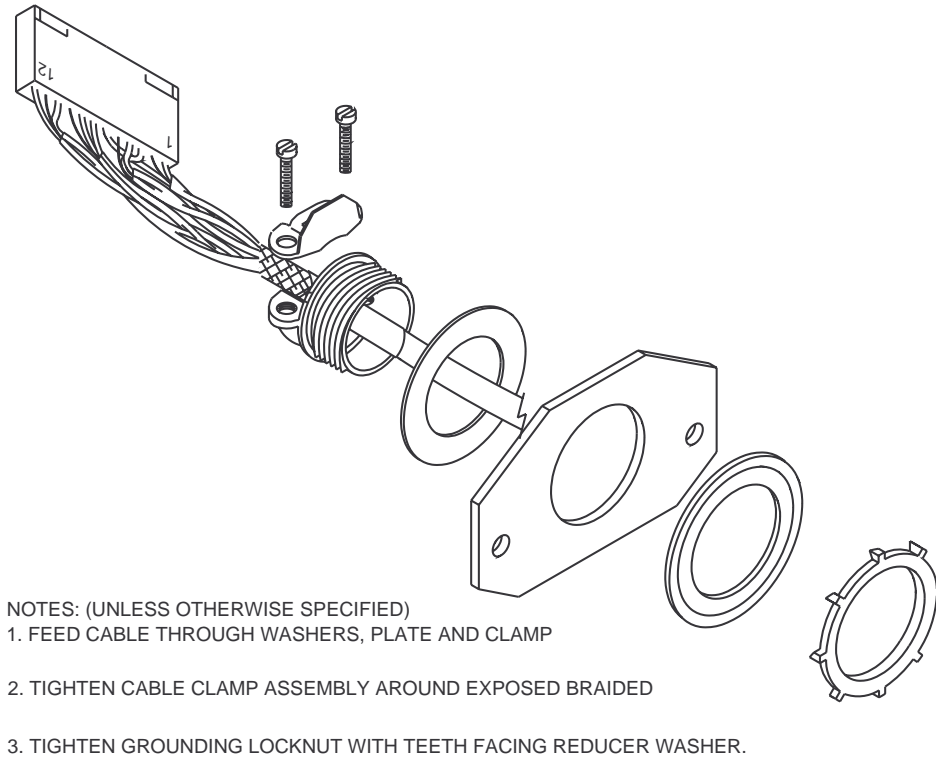

**Figure 2.2 Flywheel Mounting**

## 2.2 Electrical Connections to the Digital Soundhead

### Video Cable Mounting Assembly

The video cable is normally mounted to the Cat. No. 701 by a cable clamp, a locknut and two washers. Figure 2.3 shows the details of this mounting assembly. This method is used in non-conduit installations.



**Figure 2.3 Assembly Video Cable Clamp**

If the cable is installed in conduit, then the cable clamp assembly should be removed from the Cat. No. 701 mounting plate and replaced with the appropriate hardware for the conduit installation.

### LED Power

The Cat. No. 701 Digital Soundhead comes equipped with a 5V power supply to power the red LED. This supply is powered via an IEC mains connector on the rear of the soundhead. A 2 meter long power cord is included. Outside the United States the appropriate connector (not supplied) must be attached to the power cord. See Section 1 for the required mains connector wiring. The supply will operate on 85-265 Vac, 50-60 Hz.

## Video Cable

The video cable connects the Cat. No. 634R CCD Board in the Digital Soundhead to the CP500 or DA20. This cable must be pulled through grounded metal conduit or other shielded wireway to meet EMI emission standards. The male DB25 connector is attached to the CP500 or DA20 end of the cable; on the other end the pins for a 12-way Molex connector are inserted into the Molex connector housing. The standard cable is 10m (about 30 feet) long. 30m (about 100 feet) or 15m (about 50 feet) cables are available. An extra set of connector pins is included in case it is necessary to cut the cable for any reason.



**Plug the Molex connector onto the CCD board in the Digital Soundhead before plugging the male DB25 connector onto the DA20.**

## 2.3 Making a Custom Video Cable

The following information is included for use when a cable is being made up on site. The cable should be Belden Datalene 8164, which contains four shielded twisted pairs of computer-grade cable with the shields isolated from each other plus a 100% coverage overall shield. Using other types of cable may result in unsatisfactory operation. The overall shield is necessary to prevent RF interference signals from radiating from the video cable, causing possible complaints and violating government EMI standards. A metal shell **MUST** be used on the D-connector and the overall shield **MUST** be grounded to the connector shell to ensure proper operation and compliance with EMI regulations.

**Wiring table for DB25 end of video cable**

25 pin D-connector pin no.	Molex pin no.	Wire Color	Signal name
1			n.c.
2			n.c.
3			n.c.
4	7	Blue	TTC
5	9	Shield	TC GND
6	8	Black	FTC
7	10	White	TSC
8	11	Shield	SC GND
9	12	Black	FSC
10			n.c.
11			n.c.
12			n.c.
13			n.c.
14	1	Black	Video 0
15	2	Shield	GND
16	6	Red	+15V
17	3	Black	Video 1
18	5	Shield	GND
19	4	Green	-15V
20 through 25			n.c.

## Wiring to the Molex Connector

1. Strip back vinyl outer jacket of cable to 3.0 inches.

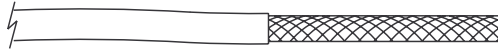

2. Add 1/2 inch dia heat-shrink about 1/4 inch long near end of vinyl outer jacket.

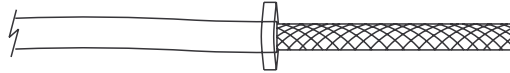

3. Fold outer shield braid back over vinyl outer jacket.

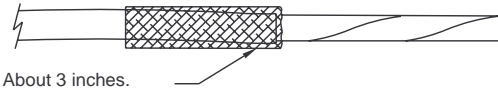

4. Trim back outer foil shield and plastic cords.

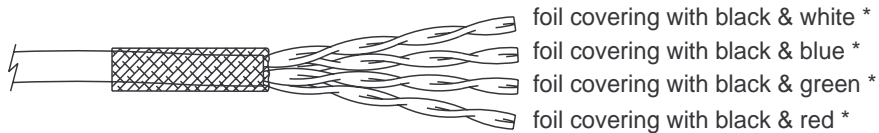

\* foil color may vary depending upon cable manufacturer

5. Install shrink tubing.

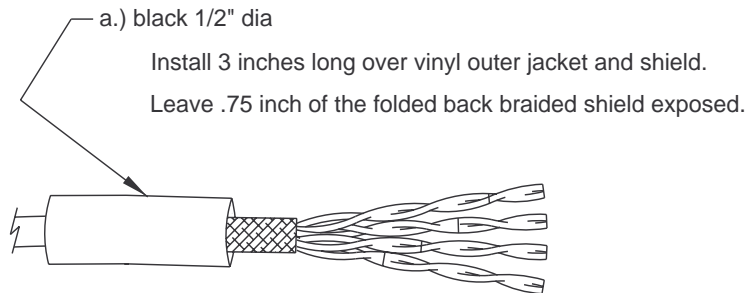

- b.) clear 1/8" dia
- 2.4 inches on foil covering with black & white \*
  - 2 inches on foil covering with black & blue \*
  - 1.5 inches on foil covering with black & green \*
  - 1.2 inches on foil covering with black & red \*

6. Strip back foil to edge of 1/8 inch shrink tubing.

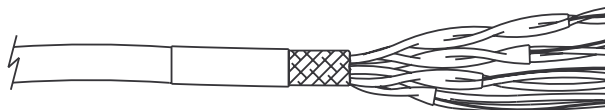



12. Install pins into Molex housing according to wiring table

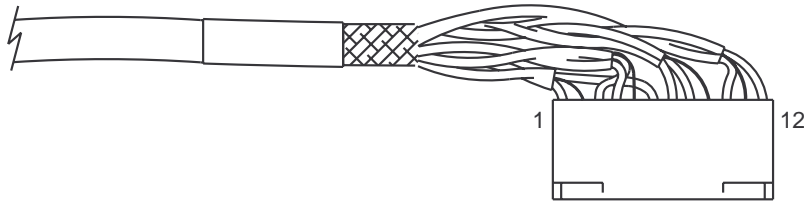

The pins must be inserted in the Molex connector block as shown in the following table.



**Perform this operation before plugging the male DB25 connector into the DA20 or CP500. Incorrect placement of pins will result in damage to the Cat. No. 634R CCD board or the Cat. No. 670 video acquisition module.**

Pin 1 is to the left when the Molex connector is connected to the Cat. No. 634R CCD Board in the Cat. No. 701 Digital Soundhead. This assembly is easiest if you insert the shortest leads first.

**Wiring table for inserting pins in red Molex connector block**

Molex pin no.	Wire color	Signal name
1	Black	Video 0
2	Shield	GND
6	Red	+15V
3	Black	Video 1
4	Green	-15V
5	Shield	GND
7	Blue	TTC
8	Black	FTC
9	Shield	TC GND
10	White	TSC
11	Shield	SC GND
12	Black	FSC

The cable clamp which is attached to the Cat. No. 700 cable mounting plate, along with the exposed braid on the video cable, provide an electrical ground path for the shield of the video cable.

This video cable shield may be isolated if necessary by loosening the 2 screws which clamp the video cable shield and installing an insulator around the braided shield (such as 1/2 inch diameter heat shrink tubing). It is important to re-tighten the cable clamp after installing the insulation to provide strain relief for the video cable.



**Plug the Molex connector onto the CCD board in the Digital Soundhead before plugging the male DB25 connector onto the DA20 or CP500.**