

# **Model CP500 Cinema Processor Reference Diagrams**

***Grounding Details  
Installation Wiring  
Connector Pin Assignments  
System Block Diagram  
Card Locations and Signal Flow  
Menu Structure***

Issue 02  
Part No. 91497  
S98/11512/12084

# Proper Grounding of Equipment

(For non-EC countries only)

In the past it was assumed that if the units were mounted in the same rack that they would be bonded together by way of the rack rails to the mounting ears. The paint used on professional products has gotten much better in the last few years and this assumption is generally no longer true. To ensure a good ground connection between units in the rack and therefore a quiet system with no hum or noise it is highly recommended installing at least one star washer for every piece of equipment. Insulating nylon or plastic washers on the rack screws should not be used with the star washer. See figure below:

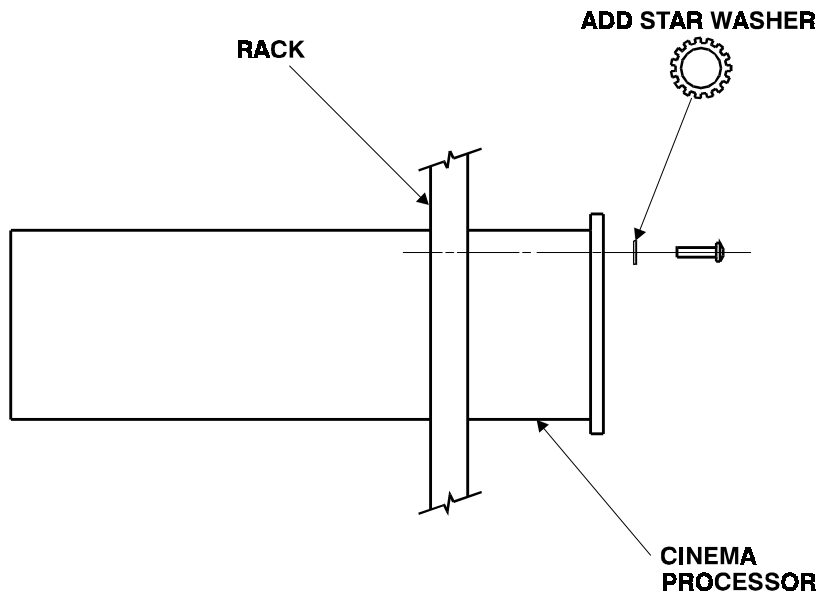

To optimize the grounding of the system you must add a jumper between signal ground of the CP500 and the chassis. See figure below:

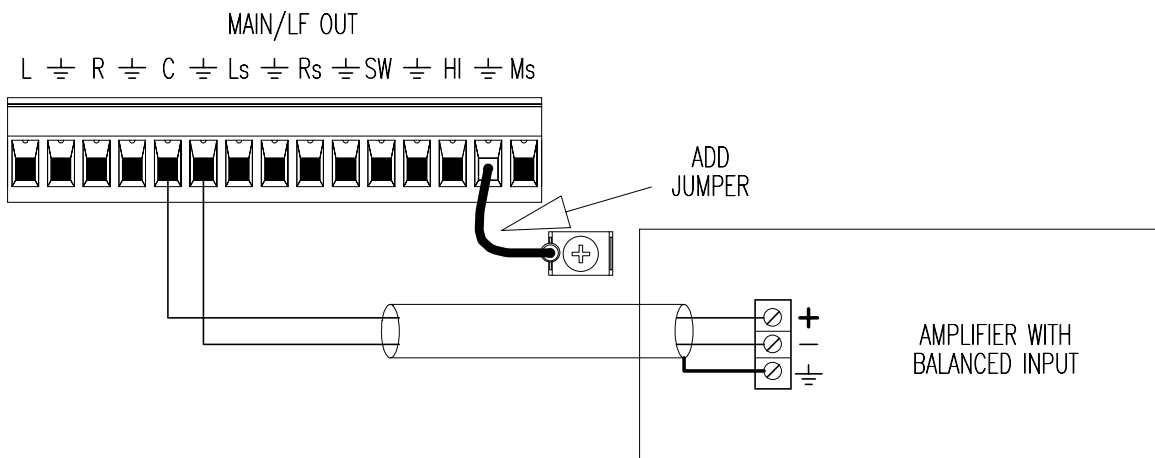

**Connection of ground jumper and amplifier**

Most projectors sold in North America come with the new reverse scan LED analog soundhead readers installed. In addition, many existing projectors are being upgraded to include this superior method of playing back SVA soundtracks. The output of the solar cell from this system is at a somewhat lower level than a normal incandescent exciter lamp solar cell. In order to provide the correct signal level for the cinema processor a small preamp board is needed and is mounted in the soundhead.

Since this is an active circuit it must have its signal ground connected to the cinema processor ground for correct operation. Failure to connect the board ground to the cinema processor can result in a noisy optical system or no sound at all. In some instances the signal ground from the board has been connected to the ground of the projector; this method should be avoided as it is not the best way to make this connection. The preferred way is to connect the shield at both ends of the signal path. See figure below:

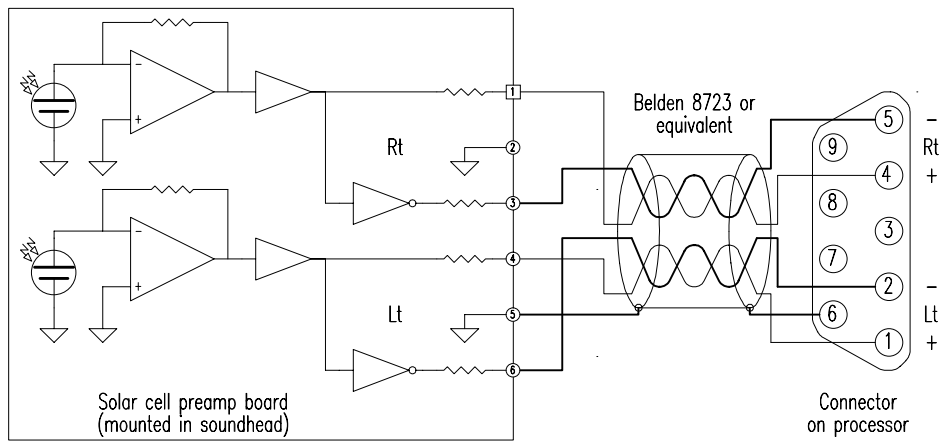
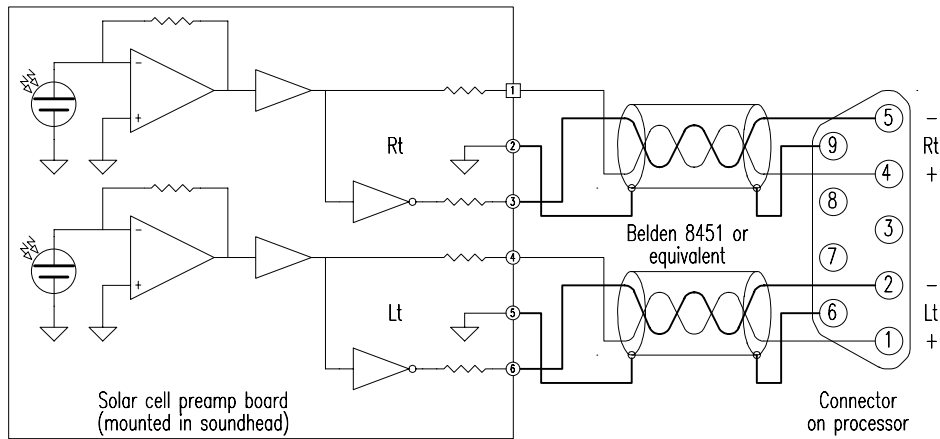

**Proper connection of Reverse Scan LED Readers to Cinema Processor**

Notes:

1. Follow all local electrical and building codes.
2. Use earthed (grounded) conduit wherever possible. Avoid routing signal wiring near electric motors, rectifiers, power wiring, dimmer wiring or other sources of electrical noise.
3. For two conductor with shield wiring, use Belden 8451 2-conductor shielded cable or equivalent: tinned copper, polypropylene insulated, twisted pair, 22 AWG stranded tinned copper drain wire, aluminum-polyester shield, paper wrap, 100 percent shield coverage, conductor to conductor (111pF per meter).
4. For three conductor with shield wiring, use Belden 8771 3-conductor shielded cable or equivalent: tinned copper, polypropylene insulated, twisted triplet, 22 AWG stranded tinned copper drain wire, aluminum-polyester shield, paper wrap, 100 percent shield coverage, conductor to conductor (75pF per meter).
5. All shields must be connected to the CHASSIS of the CP500 rather than to circuit (audio) ground. This achieves the required RF interference immunity. In D-connectors, a metal housing must be used and the shields must be connected to the housing.
6. In order to provide maximum protection against electrostatic discharge and conform to European EMC standards, the green plastic housings included in the shipping materials MUST be installed over the rectangular connectors. Assemble the cables so that the shield wire exits the rear of the plastic housing. Make the shield wire long enough to reach the push-on terminal on the rear panel. Attach the supplied terminal. Slide the shield wire on to the push-on terminal on the rear panel. If any of the rectangular connectors are not used, assemble the plug and green housing and install the plug into the unused backplane connector.

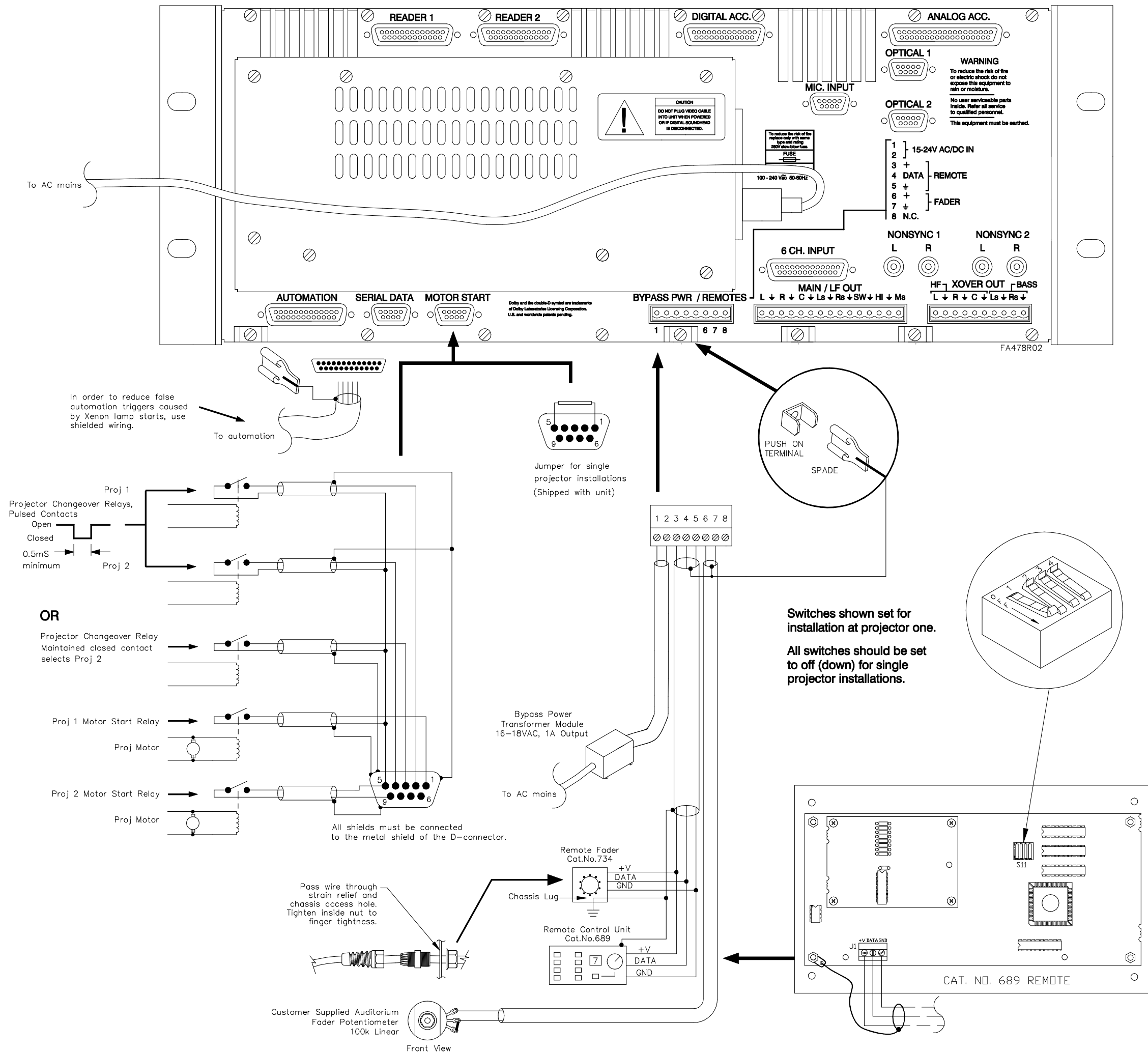

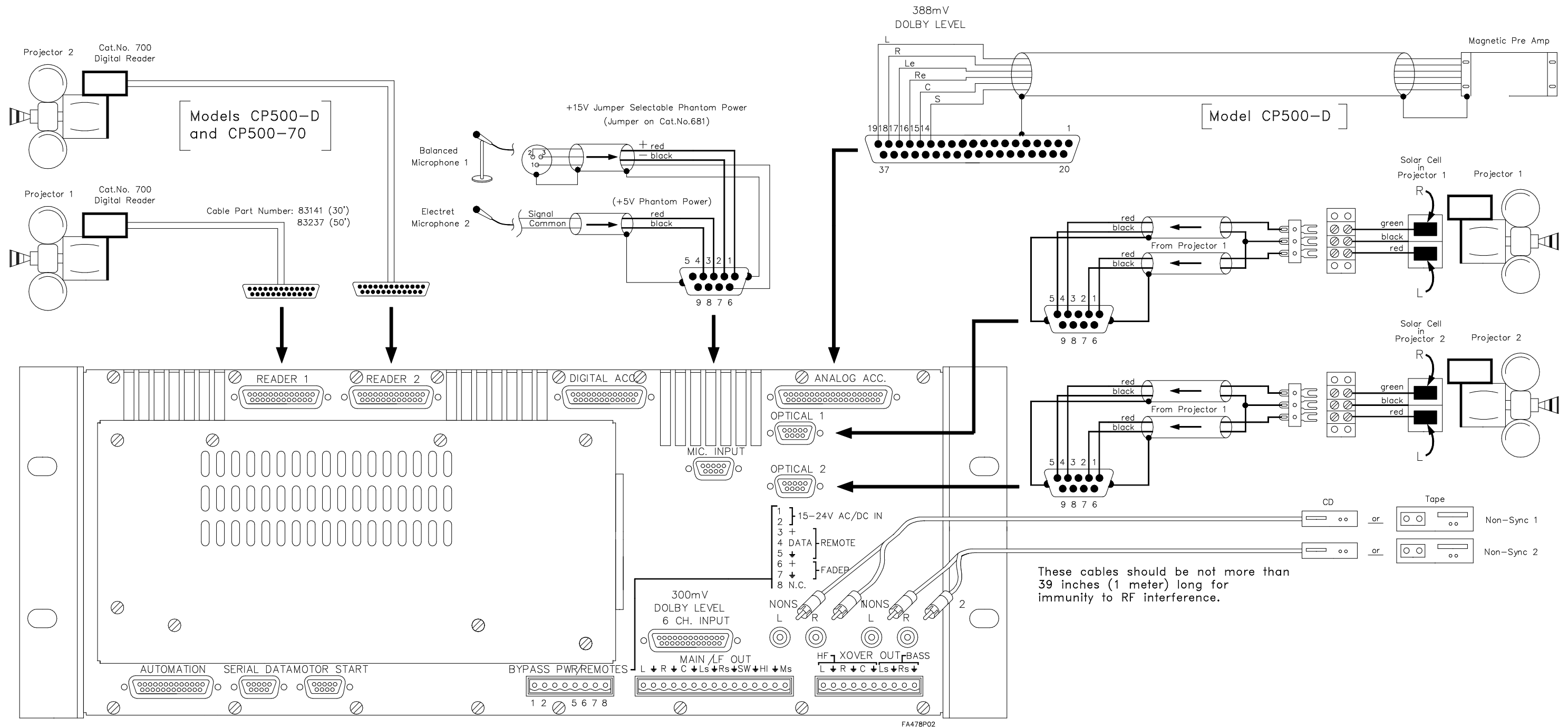

**Notes:**

1. Follow all local electrical and building codes.
2. Use earthed (grounded) conduit wherever possible. Avoid routing signal wiring near electric motors, rectifiers, power wiring, dimmer wiring or other sources of electrical noise.
3. For two conductor with shield wiring, use Belden 8451 2-conductor shielded cable or equivalent: tinned copper, polypropylene insulated, twisted pair, 22 AWG stranded tinned copper drain wire, aluminum-polyester shield, paper wrap, 100 percent shield coverage, conductor to conductor (111pF per meter).
4. For three conductor with shield wiring, use Belden 8771 3-conductor shielded cable or equivalent: tinned copper, polypropylene insulated, twisted triplet, 22 AWG stranded tinned copper drain wire, aluminum-polyester shield, paper wrap, 100 percent shield coverage, conductor to conductor (75pF per meter).
5. All shields must be connected to the CHASSIS of the CP500 rather than to circuit (audio) ground. This achieves the required RF interference immunity. In D-connectors, a metal housing must be used and the shields must be connected to the housing.
6. For connection details using red led-type analog readers, see manual section 3.

## APPENDIX C

### BACKPLANE CONNECTORS / REFERENCE DIAGRAMS

---

## CP500 Backplane Connector Pin Assignments

### 1. Automation Connector:

Pin Number	Function
1	SK1 Format Select Input
2	SK2 Format Select Input
3	SK3 Format Select Input
4	SK4 Format Select Input
5	SK5 Format Select Input
6	SK6 Format Select Input
7	SK7 Format Select Input
8	SK8 Format Select Input/or STEP (in Automation Sequential mode)
9	Mute On/Off Input
18	Format Status Bit 0
19	Format Status Bit 1
20	Format Status Bit 2
25	Projector Status Output
12	Signal Ground

### 2. Serial Data Connector:

Pin Number	Signal Name
1	N/C
2	Transmitted Data
3	Received Data
4	Looped back to pin 6
5	Signal Ground
6	Looped back to pin 4
7	Looped back to pin 8
8	Looped back to pin 7
9	N/C

### 3. Motor Start Connector:

Pin Number	Signal Name
1	Motor Start Relay, Proj 1
2	Proj 1 Changeover, pulsed contacts
3	Changeover relay, closed selects Proj 2
4	Proj 2 Changeover, pulsed contacts
5	Ground
6	N/C
7	N/C
8	N/C
9	Motor Start Relay, Proj 2

**4. Bypass / Remote Connector:**

<b>Pin Number</b>	<b>Signal Name</b>
1	Bypass Power Transformer Connection, 16-18 Vac
2	Bypass Power Transformer Connection, 16-18 Vac
3	Remote Control Unit V+
4	Remote Control Unit Data
5	Remote Control Unit Ground
6	Remote Auditorium Fader +
7	Remote Auditorium Fader Ground
8	N/C

**5. Main / LF Output Connector:**

<b>Pin Number</b>	<b>Signal Name</b>
1	Left Channel
2	Signal Ground
3	Right Channel
4	Signal Ground
5	Center Channel
6	Signal Ground
7	Left Surround Channel
8	Signal Ground
9	Right Surround Channel
10	Signal Ground
11	Sub Woofer Channel
12	Signal Ground
13	Hearing Impaired Channel
14	Signal Ground
15	Mono Surround Channel

**6. Crossover Output Connector (Used With Cat. No. 683 Installed):**

<b>Pin Number</b>	<b>Signal Name</b>
1	Left Channel HF
2	Signal Ground
3	Right Channel HF
4	Signal Ground
5	Center ChannelHF
6	Signal Ground
7	Left Surround Channel LF
8	Signal Ground
9	Right Surround Channel LF
10	Signal Ground

**7. Optical 1 Input Connector:**

<b>Pin Number</b>	<b>Signal Name</b>
1	Projector 1 Left Channel +
2	Projector 1 Left Channel -
3	Signal Ground
4	Projector 1 Right Channel +
5	Projector 1 Right Channel -
6	Signal Ground
7	N/C
8	N/C
9	Signal Ground

**8. Optical 2 Input Connector:**

<b>Pin Number</b>	<b>Signal Name</b>
1	Projector 2 Left Channel +
2	Projector 2 Left Channel -
3	Signal Ground
4	Projector 2 Right Channel +
5	Projector 2 Right Channel -
6	Signal Ground
7	N/C
8	N/C
9	Signal Ground

**9. Mic. Input Connector:**

<b>Pin Number</b>	<b>Signal Name</b>
1	Mic1+
2	Mic1-
3	Mic2 signal
4	Mic2 ground
5	N/C
6	Mic1 ground
7	Mic Multiplexer V+
8	Mic Multiplexer Gnd
9	Mic Multiplexer Data

## 10. Accessory Rack Analog Connector:

Pin Number	Signal Name	Signal Description
1	AccOptByb	Mono input to Cat 682 for Bypass Operation
2	X15	Direct Input to Cat 682
3	X14	Direct Input to Cat 682
4	X13	Direct Input to Cat 682
5	X12	Direct Input to Cat 682
6	X11	Direct Input to Cat 682
7	X10	Direct Input to Cat 682
8	AccSW	Ouput to Acc Rack from Cat 662
9	AccC	Ouput to Acc Rack from Cat 662
10	AccRS	Ouput to Acc Rack from Cat 662
11	AccLS	Ouput to Acc Rack from Cat 662
12	AccR	Ouput to Acc Rack from Cat 662
13	AccL	Ouput to Acc Rack from Cat 662
14	AccNRS	Input to noise reduction resources*
15	AccNRC	Input to noise reduction resources*
16	AccNRRe	Input to noise reduction resources*
17	AccNRLe	Input to noise reduction resources*
18	AccNRR	Input to noise reduction resources*
19	AccNRL	Input to noise reduction resources*
20	Ground	Signal Ground
21	Ground	Signal Ground
22	Ground	Signal Ground
23	Ground	Signal Ground
24	Ground	Signal Ground
25	Ground	Signal Ground
26	Ground	Signal Ground
27	Ground	Signal Ground
28	Ground	Signal Ground
29	Ground	Signal Ground
30	+13VDC	Power Supply
31	+13VDC	Power Supply
32	-12VDC	Power Supply
33	-12VDC	Power Supply
34	Ground	Signal Ground
35	OPTBUSSR	Optical Pre Amp Output Right Channel
36	Ground	Signal Ground
37	OPTBUSSL	Optical Pre Amp Output Left Channel

---

\* Dolby Level is 388 mV.

## 11. Accessory Rack Digital Connector:

Pin Number	Signal Name	Signal Description
1	Signal Ground	Signal Ground
2	OPTLRCK	Left / Right Clock from Optical A/D
3	RETS2D	Serial Data 2 Return
4	RETS1D	Serial Data 1 Return
5	RETS0D	Serial Data 0 Return
6	RETWCK	Word Clock Return
7	RETBCK	Serial Bit Clock Return
8	ACCBAUD	Baud Rate Clock
9	ACCLINK	Accessory Rack Present
10	RET256FS	256 X Sample Rate Clock Return
11	ACCRXD	Accessory Rack Received Data
12	ACCTXD	Accessory Rack Trasmitted Data
13	Signal Ground	Signal Ground
14	OPTBCK	A/D Bit Clock form Optical A/D
15	OPTDAT	Serial Data from Optical A/D
16	RETOPTD AT1	Spare Data Line 1
17	RETOPTD AT2	Spare Data Line 2
18	!ACCEN	Enable Accessory Rack
19	ACCSD2	Accessory Rack Serial Data 2
20	ACCWCK	Accessory Rack Word Clock
21	ACCBCK	Accessory Rack Bit Clock
22	ACCSD1	Accessory Rack Serial Data 1
23	ACC256FS	Accessory Rack 256 X Sample Rate Clock
24	ACCSD0	Accessory Rack Serial Data 0
25	ACC512FS	Accessory Rack 512 X Sample Rate Clock

**12. 6 Channel Input Connector\* :**

<b>Pin Number</b>	<b>Signal Name</b>	<b>Signal Description</b>
1	Signal Ground	
2	EXT3	Right Surround Channel External Input
3	Signal Ground	
4	Signal Ground	
5	Signal Ground	
6	Signal Ground	
7	Signal Ground	
8	Signal Ground	
9	Signal Ground	
10	Signal Ground	
11	Signal Ground	
12	Signal Ground	
13	Signal Ground	
14	EXT0	Left Channel External Input
15	EXT2	Left Surround Channel External Input
16	Signal Ground	
17	EXT1	Right Channel External Input
18	Signal Ground	
19	Signal Ground	
20	EXT4	Center Channel External Input
21	Signal Ground	
22	Signal Ground	
23	Signal Ground	
24	EXT5	Sub Woofer Channel External Input
25	Signal Ground	

---

\* Dolby Level is 300 mV at these set of inputs.

**13. Reader 1 and Reader 2 Input Connector:**

<b>Pin Number</b>	<b>Signal Name</b>	<b>Signal Description</b>
1	N/C	
2	N/C	
3	N/C	
4	TTCO	Row Clock Return
5	TCOGND	Row Clock Common
6	FTCO	Row Clock Send
7	TSCO	Pixel Clock Return
8	SCOGND	Pixel Clock Common
9	FSCO	Pixel Clock Send
10	N/C	
11	N/C	
12	N/C	
13	N/C	
14	VO	Differential Video V0
15	VOGND	V0 Common
16	+15VIDEO	+15VDC
17	V1	Differential Video V1
18	V1GND	V1 Common
19	-15VIDEO	-15VDC
20	N/C	
21	N/C	
22	N/C	
23	N/C	
24	N/C	
25	N/C	

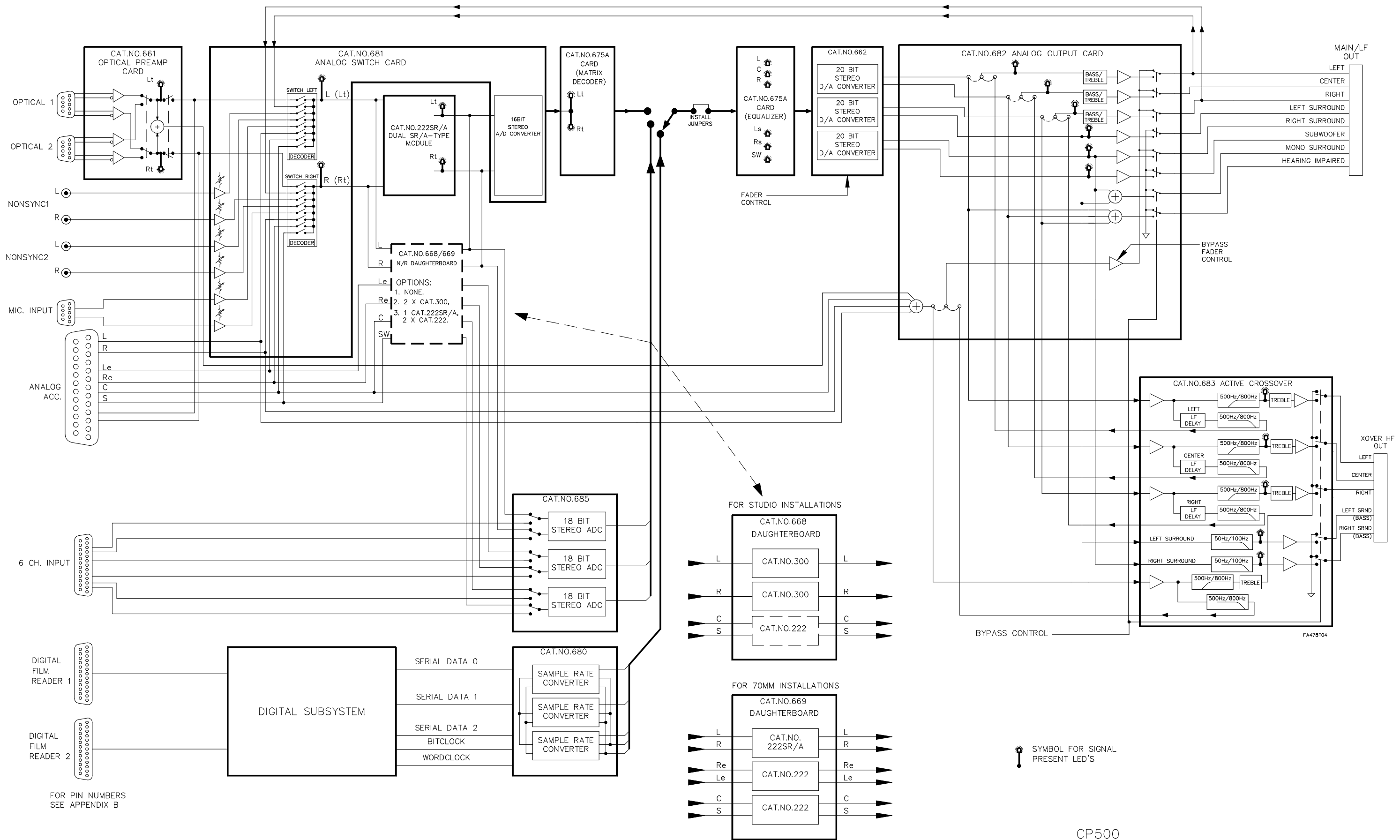

FOR PIN NUMBERS  
SEE APPENDIX B

SYMBOL FOR SIGNAL  
PRESENT LED'S

CP500  
SIGNAL BLOCK DIAGRAM

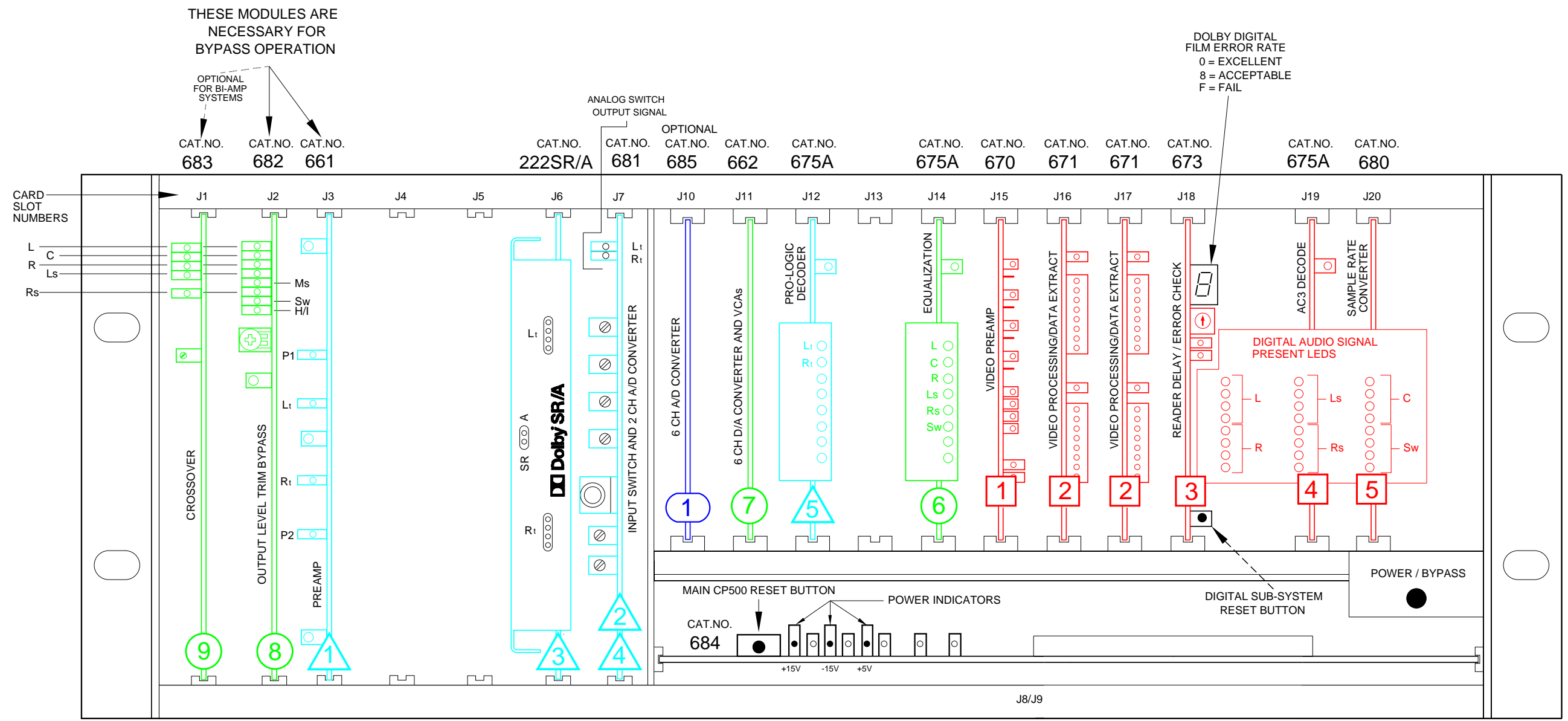

### SIGNAL PATHS

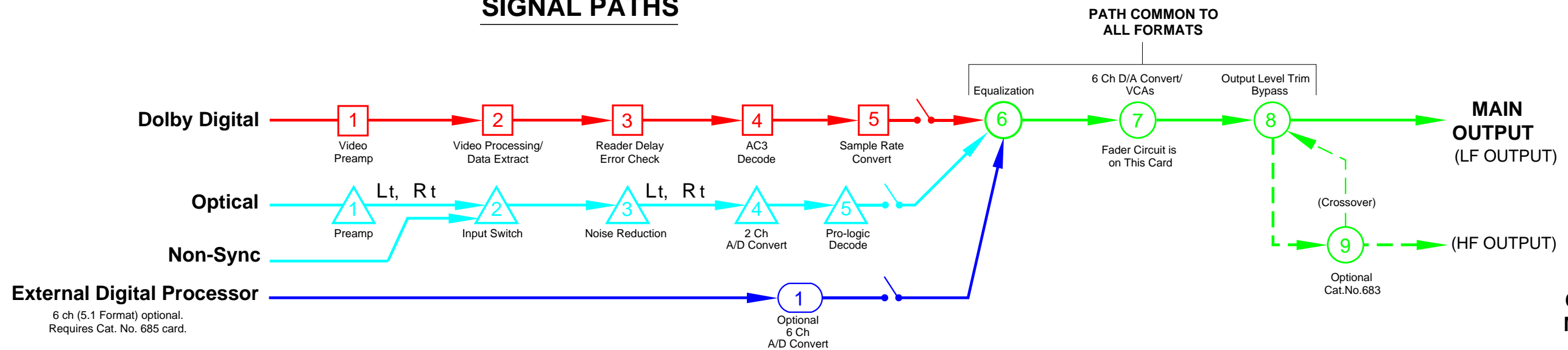

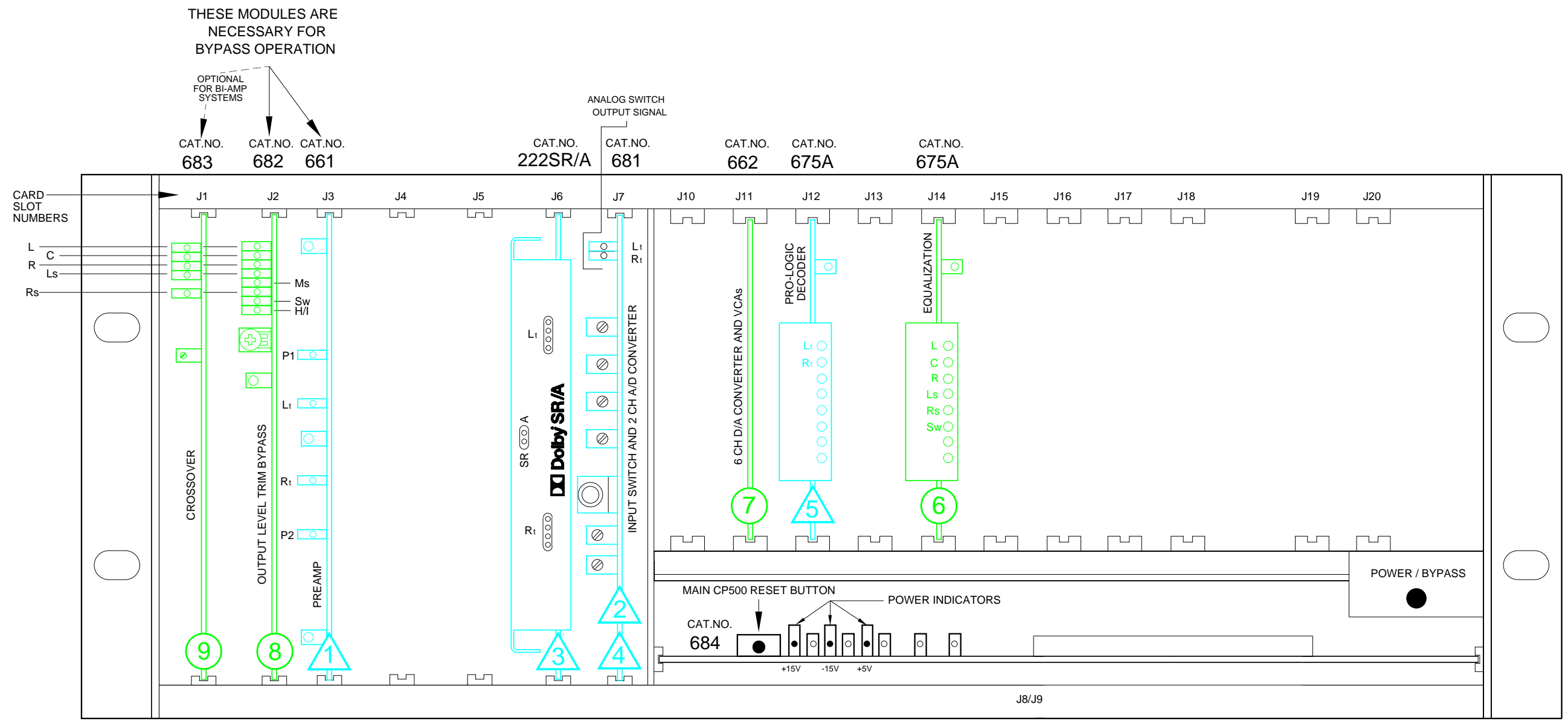

## SIGNAL PATH

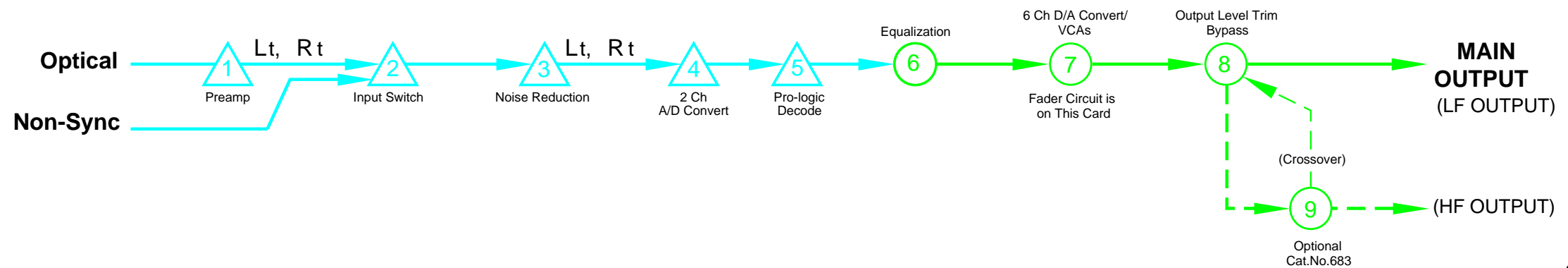

CARD LOCATIONS  
MODEL CP500-SR

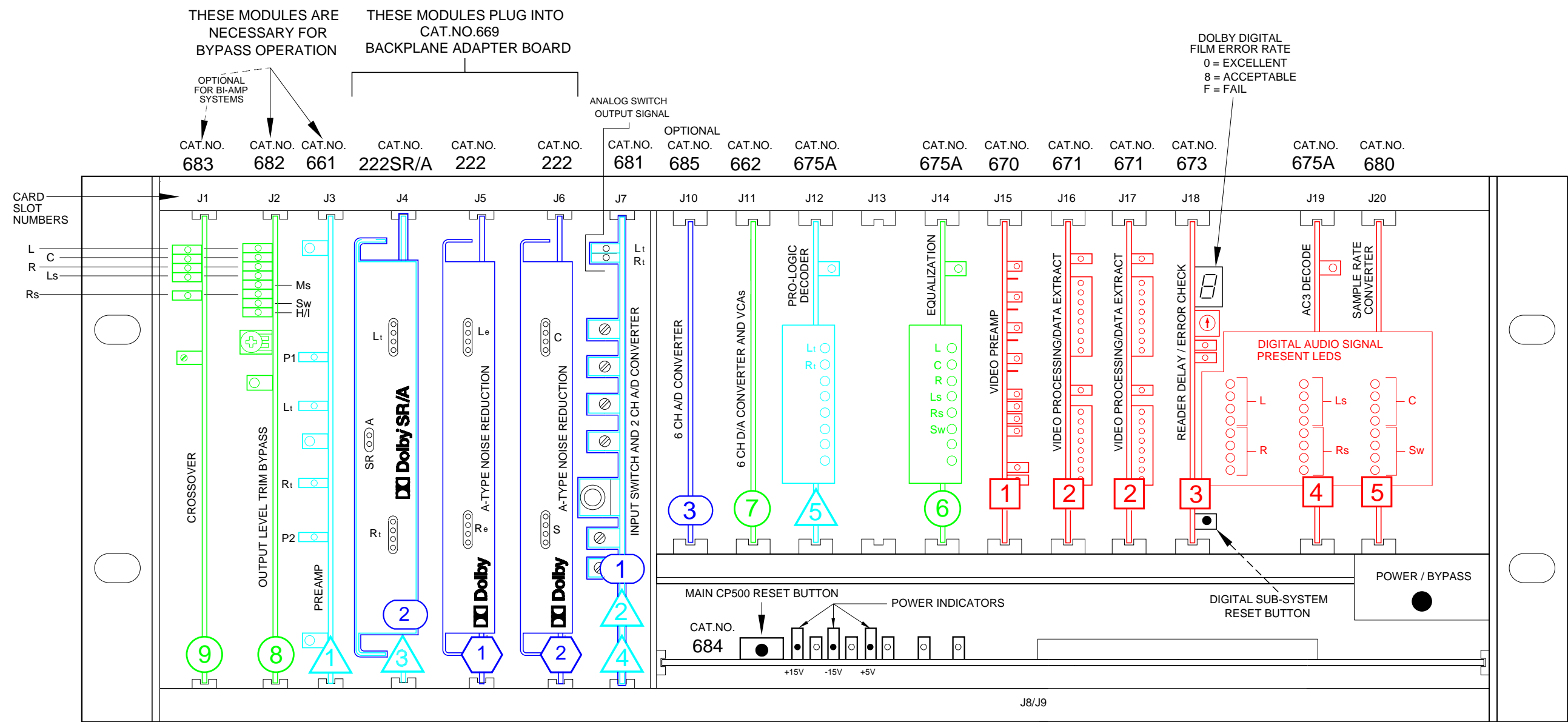

### SIGNAL PATHS

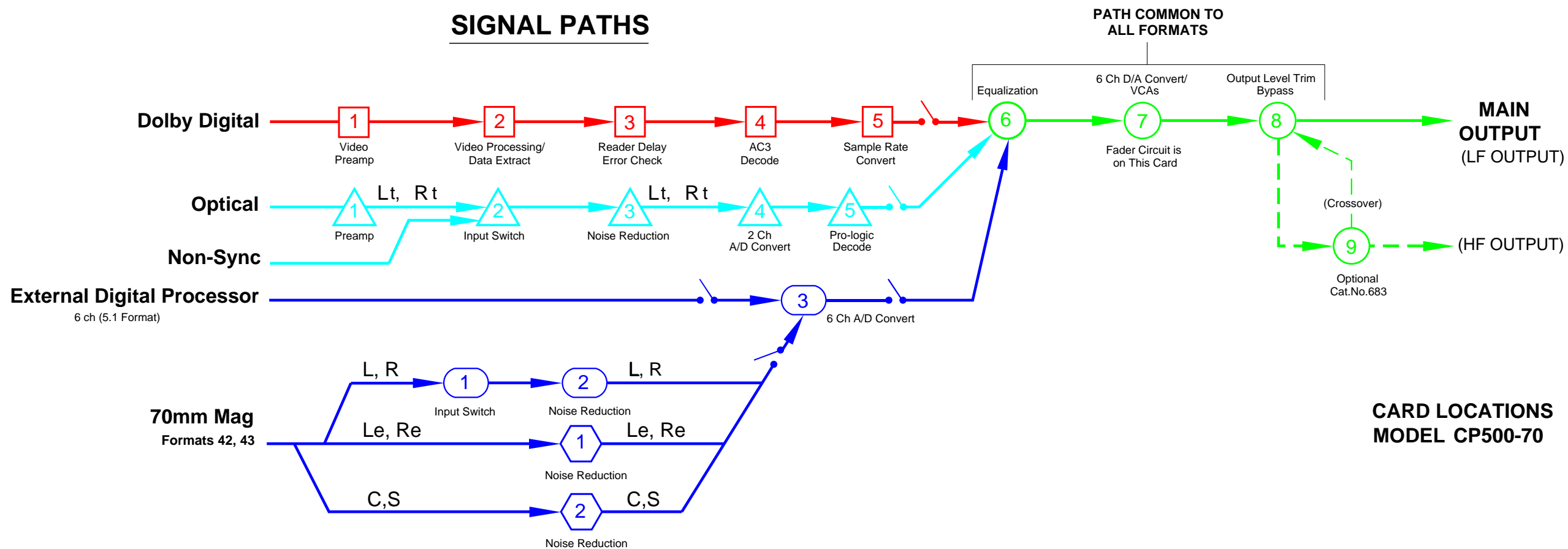

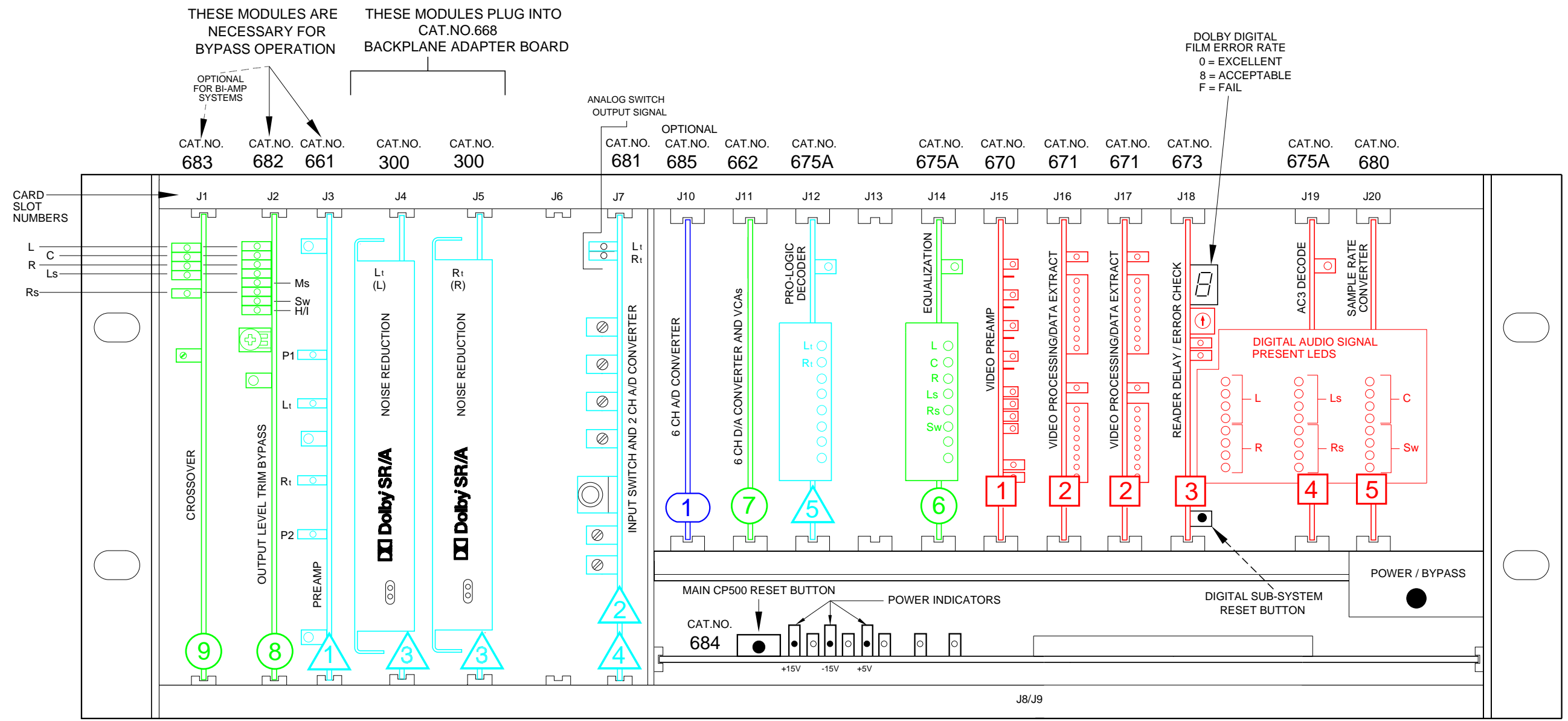

### SIGNAL PATHS

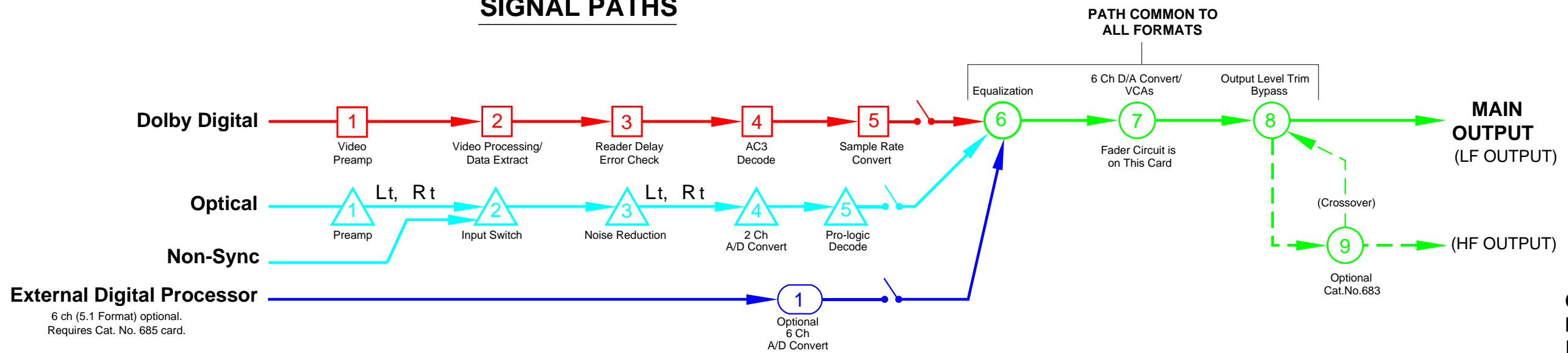

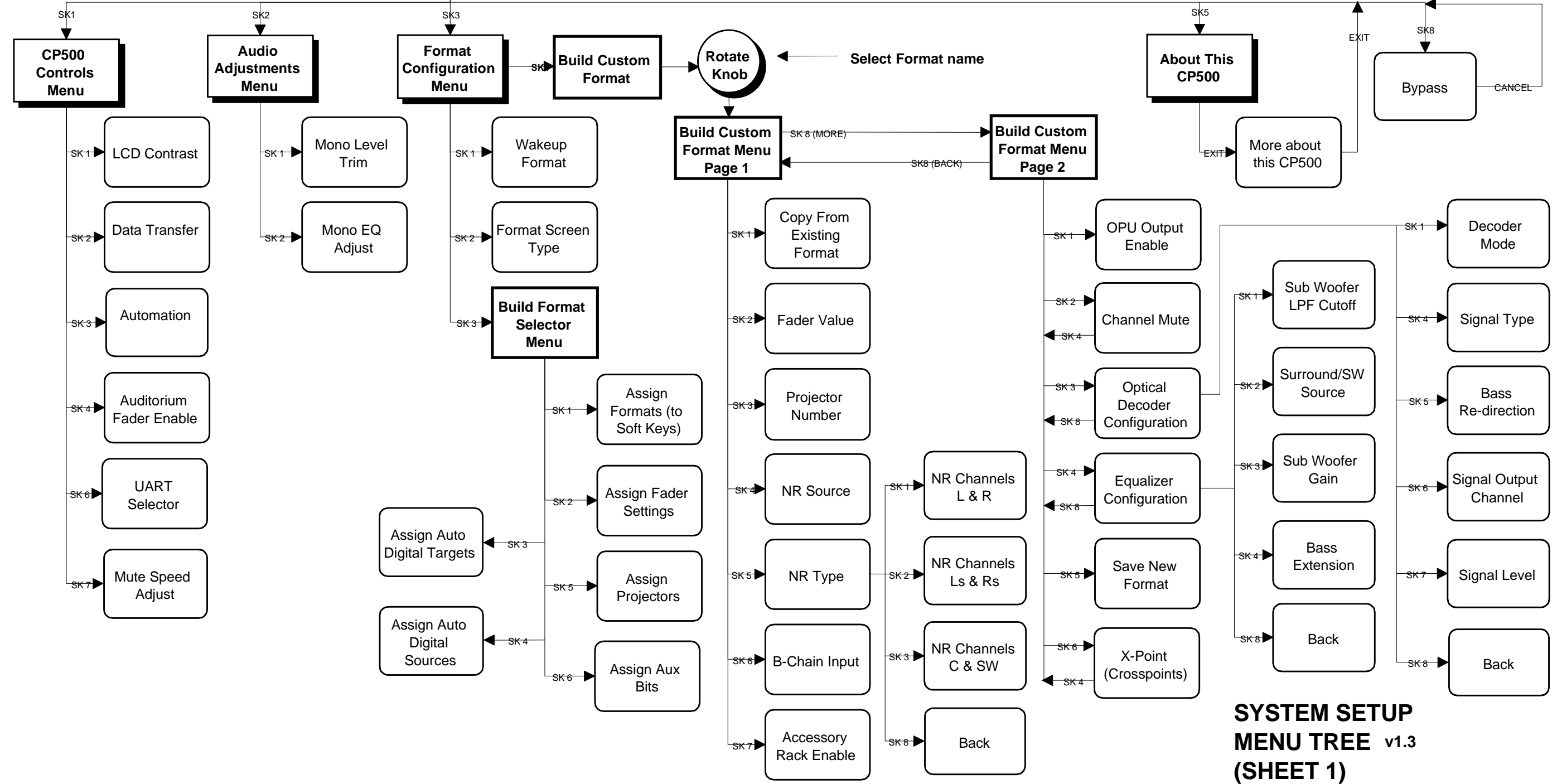
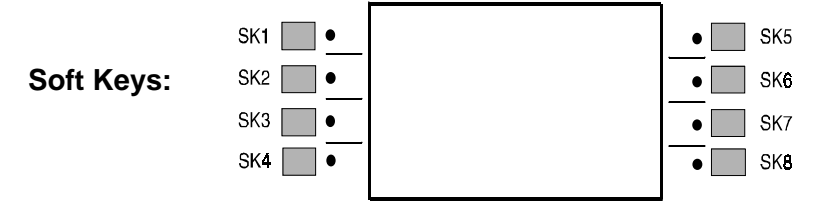
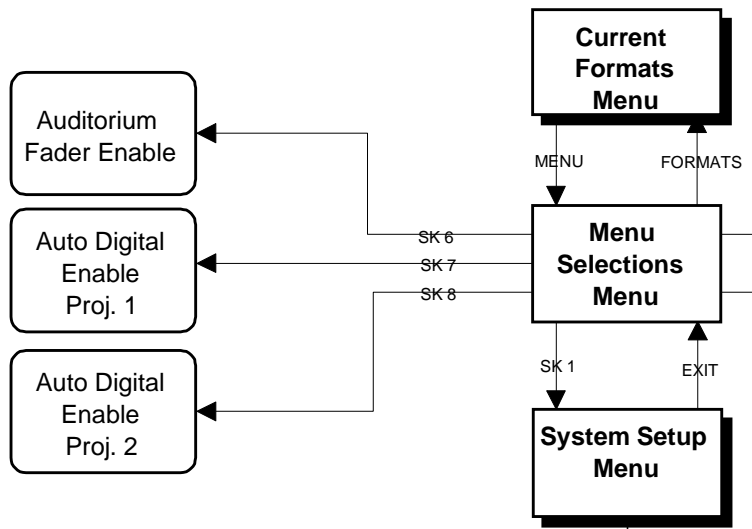

**SYSTEM SETUP  
MENU TREE v1.3  
(SHEET 1)**  
TREE1\_03.FLO

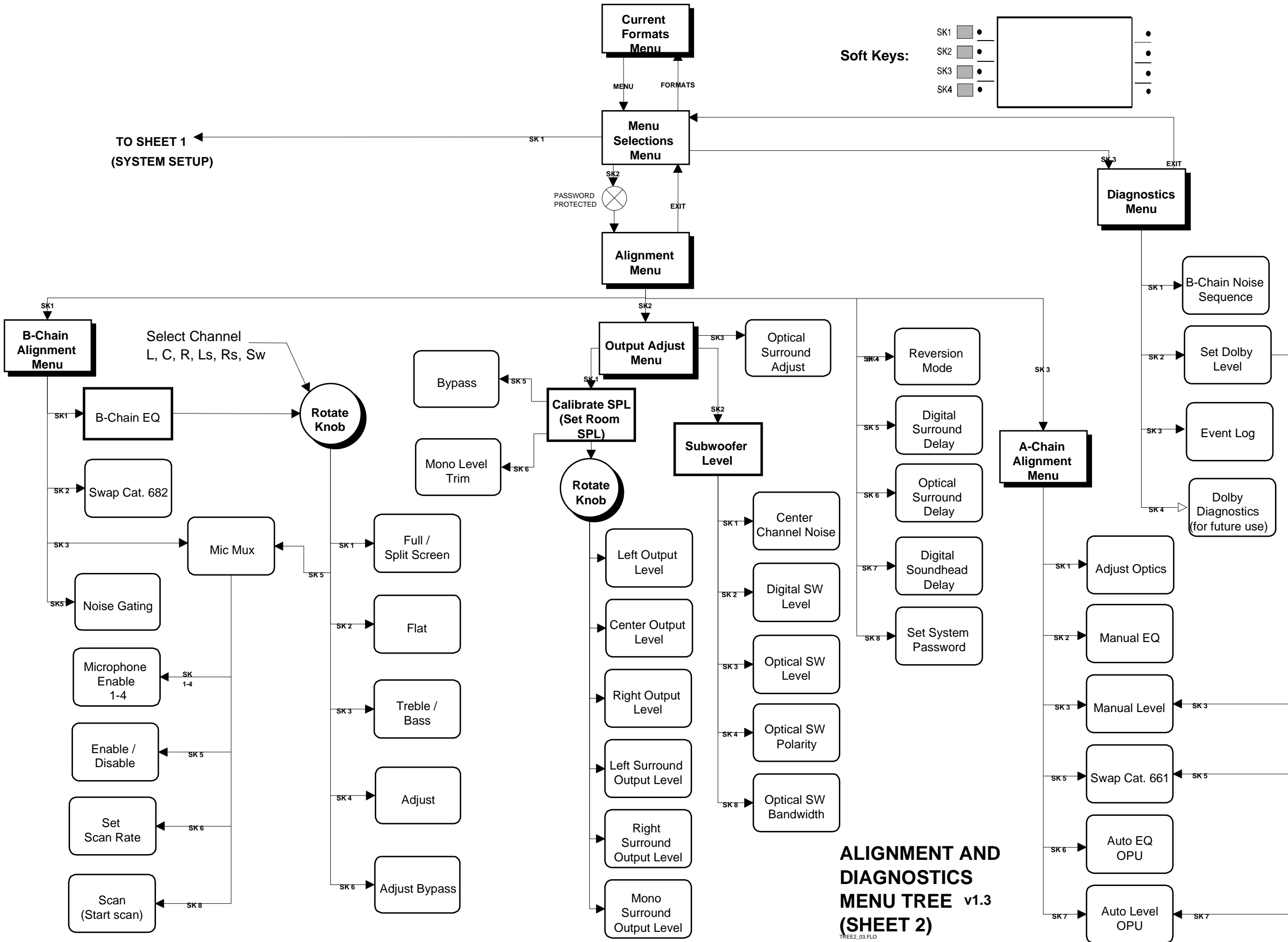

**ALIGNMENT AND DIAGNOSTICS MENU TREE v1.3 (SHEET 2)**  
TREE2\_03.FLO