

Bliz Whiz

Part No. 12069
Revised June 1996

Ice Shaver Instruction Manual Model #1001



 **GOLD MEDAL**®

FUNFOOD EQUIPMENT & SUPPLIES

Cincinnati, OH 45241-4807 USA

SAFETY PRECAUTIONS

	⚠ CAUTION
	This equipment is designed and sold for commercial use only. This equipment is not to be used by the consumer in home use. Do not allow direct contact of this equipment by the public when used in food service locations. Only personnel trained and experienced in the equipment operation may operate this equipment. Carefully read all installation instructions before operating the equipment.

	⚠ WARNING
	Always wear safety glasses when servicing this equipment.

	⚠ WARNING
	Never put your fingers or any object into the shaver body (the gooseneck) while the motor is running. Serious injury may occur. <i>(Gold Medal Products does not assume any liability for injury due to careless handling and/or reckless operation of this equipment).</i>

	⚠ WARNING
	Any alterations to this equipment will void the warranty and may cause a dangerous situation. NEVER make alterations to the equipment.

	⚠ DANGER
	Machine must be properly grounded to prevent electrical shock to personnel. Do NOT immerse the equipment in water. Always unplug the equipment before cleaning or servicing.

NOTE

The information, specifications and illustrations contained in this manual represent the latest data available at time of publication. Right is reserved to make changes as required at the discretion of Gold Medal Products Company without notice.

INSTALLATION

MACHINE DESCRIPTION

The *Bliz Whiz* is a compact automatic shaver with a tremendous capacity. You will find that it keeps up with any demand; as soon as you put ice into the hopper, it is shaved into fine snow.

ELECTRICAL REQUIREMENTS

The *Bliz Whiz* operates on 120 volt, single phase, 60 cycle AC current. Be sure that your electrical supply meets this requirement.

ICE REQUIREMENTS

The *Bliz Whiz* can take ice cubes or block ice, if you break the block into pieces approximately 3 to 4 inches in size. **NOTE:** The ice will not enter the shaving chute if the pieces are too large. The design of the shaving chute automatically draws the ice against the blades. There is no need for manual effort.

OPERATING INSTRUCTIONS

MACHINE OPERATION

At the base of the machine are switches marked MOTOR and LIGHT.

TO LIGHT THE DISPLAY AREA

Flip the switch marked LIGHT. You should leave the light on during your operating time. Return the switch to the "OFF" position to turn the light off.

TO SHAVE ICE

Flip the switch marked MOTOR. You may begin to place ice into the hopper. When you are finished shaving, return switch to the "OFF" position. (*See the CAUTION page, at the beginning of this manual, for important safety information.*)

OPERATING HINTS

You can really make a lot of ice in a short time with the *Bliz Whiz*, but don't let the ice pile up and block the discharge chute. This will jam the machine. If this situation were to happen :

1. Turn the MOTOR switch to the OFF position.
2. Clear the ice out of the machine with a piece of wood.
3. Allow the remainder of the ice in the machine to melt.
4. The *Bliz Whiz* should now be ready for operation.

NOTE: Never allow any foreign or metallic objects around the shaver area of the *Bliz Whiz*. Blades are often damaged by ice picks and scoops, and debris that may be in the ice.

BLIZ WHIZ CLEANING

The outer frame of your *Bliz Whiz* should be cleaned with our Nev-R-Dull polish. This will maintain the original high polish finish of your machine.

Clean all other surfaces with a mild soap and water solution. Dry with a clean, soft cloth.

MAINTENANCE INSTRUCTIONS

	⚠ CAUTION
	<p>THE FOLLOWING SECTIONS OF THIS MANUAL ARE INTENDED ONLY FOR QUALIFIED SERVICE PERSONNEL WHO ARE FAMILIAR WITH ELECTRICAL EQUIPMENT. THESE ARE NOT INTENDED FOR THE OPERATOR.</p>

	⚠ WARNING
	<p>Adequate eye protection must be used when servicing this equipment to prevent the possibility of injury.</p>

	⚠ DANGER
	<p>Do NOT immerse the equipment in water. Unplug your machine before servicing.</p>

GENERAL MAINTENANCE

The drive motor bearings are sealed and require no additional lubrication. The shaving mechanism bearings are made of a special material that require no additional lubrication. To put it simply, there is no need to lubricate this equipment.

DRIVE SHAFT ADJUSTMENT

The drive shaft needs to be adjusted when you hear excessive noise in the shaver head or if you see aluminum shavings in the case. The following adjustment should be made periodically as your equipment wears. To adjust the drive shaft to remove play:

1. Unplug the main power supply cord from the electrical outlet.
2. Remove the lock nuts from the motor and the light switches.
3. Remove the nameplate, and push the switches inward. Now lift off the dome.
4. A brass adjusting screw with a brass jam nut is coming through the cover at the far left rear of the hopper. Loosen the jam nut and turn the screw clockwise until the noise has stopped.
5. Re-tighten the jam nut.
6. Replace dome, switches, nameplate and lock nuts.

INSTALLING NEW SHAVER BLADES

Inspect your equipment before replacing the blades. Use a flashlight to examine the blades in the shaver body. If the blades appear to be nicked or bent, then the blades should be replaced.

Follow this procedure:

1. Unplug the main power supply cord from the electrical outlet.
2. Remove the lock nuts from the motor and the light switches.
3. Remove the nameplate, and push the switches inward.
4. Lift off the dome.
5. Remove the motor mounting bolts. Slide the motor out of the coupling.
6. Remove the four bolts that hold the shaving mechanism.
7. Lift the shaving mechanism from the case.
8. Pull apart the two halves of the shaving mechanism. The cutterhead will now be exposed.
9. Remove the blades from the cutterhead. These blades may be resharpened, but it is far better to replace the old blades with a new set.
10. Position the new blades and insert screws until they are finger tight.
11. Set the blade thickness equal to a penny. (See illustration below.) Make sure that the height is even across the cutterhead.

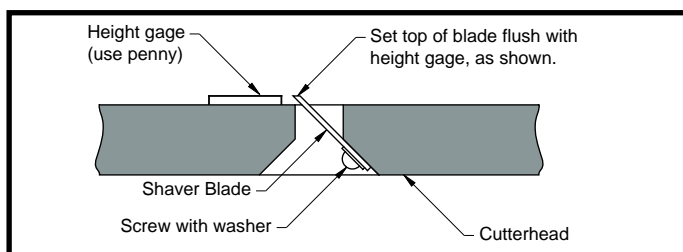

12. Tighten the blade screws completely. Check the blades again with a penny to ensure the blades did not move while tightening the screws.
13. Reassemble the unit reversing the steps above.

NOTE:

Replace the shims that were between the motor base and the mounting surface. The motor shaft must be in alignment with the shaver drive shaft. Misalignment will cause the motor coupling to wear rapidly.

REPLACING THE HOPPER CASTING BEARINGS

The bearings in the hopper casting will become worn after a lot of use. The shaver head may begin to vibrate when the bearings become worn. Worn bearings should be removed and new bearings pressed into the casting. (See diagram below for part numbers.)

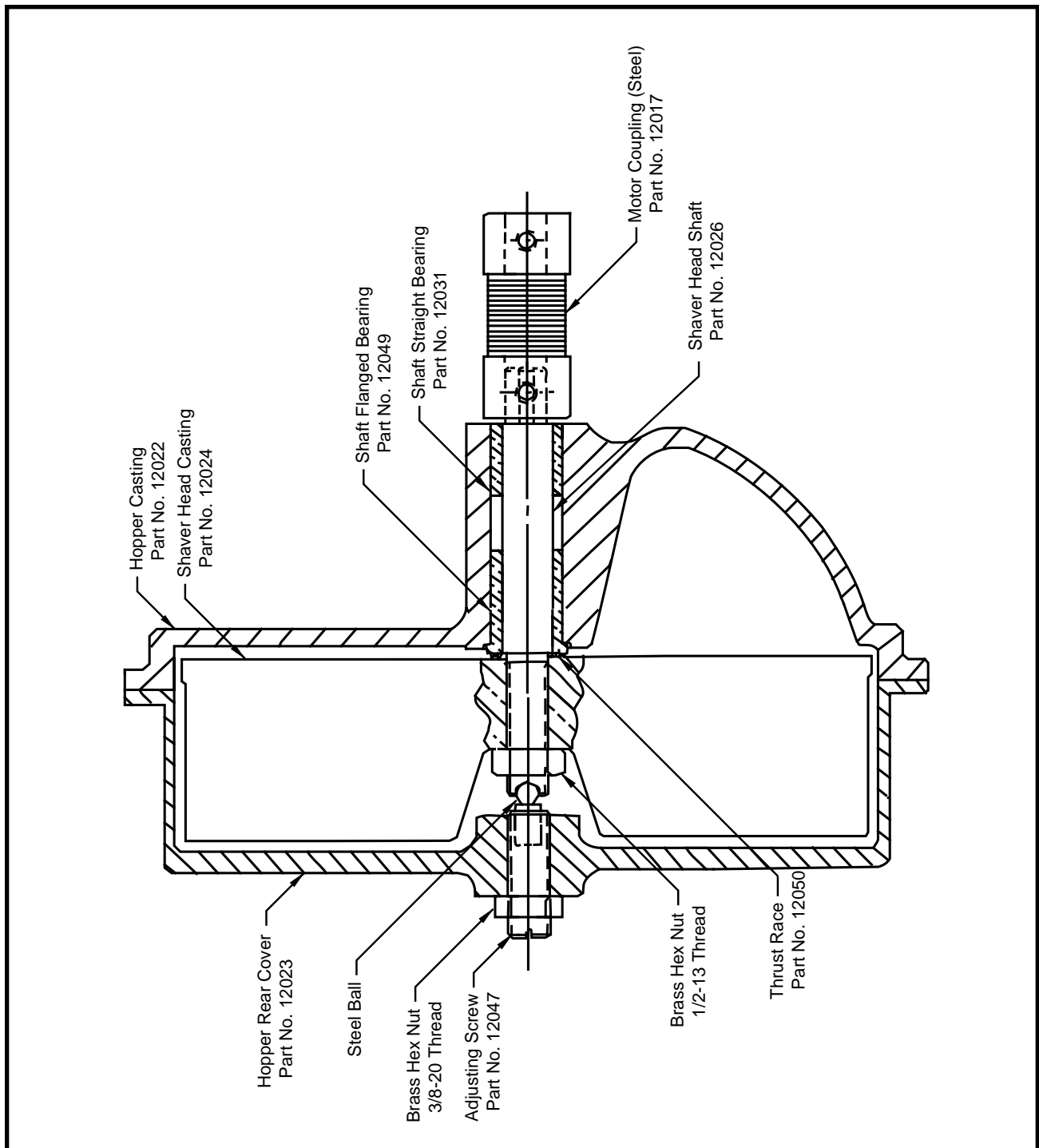

ORDERING SPARE PARTS

1. Identify the desired part by checking it against the photos, illustrations, and/or the parts list.
2. When ordering, please include part number, part name, and quantity desired.
3. Please include your model name and machine serial number (located on the machine nameplate) with your order.
4. Address all parts orders to:

Parts Department
Gold Medal Products Co.
10700 Medallion Drive
Cincinnati, Ohio 45241-4807

or, place orders at:

(513) 769-7676
Fax: (513) 769-8500
E-mail: goldme19@eos.net

SPARE PARTS

	Part Number	Description
Hopper and Shaver Parts	12017	Drive Motor Coupling
	12022	Hopper Assembly with Bearings
	12023	Hopper Rear Cover Casting
	12024	Shaver Head Casting
	12026	Shaver Head Shaft Assembly
	12027	Machined Lid Casting
	12028	3-hole Blade
	12047	Adjusting Screw Assembly
	12049	Power Shaft Flanged Bushing
	12050	Plated Thrust Bearing
	12055	1/2-20 Brass Hex Nut
	12056	1/2-13 Brass Hex Nut
	39022	120 Volt, 60 Cycle Drive Motor
	41013	Door Knob
Lights and Electric Controls	12020	Switch Bracket (Motor & Light)
	22038	Lead-in Cord, 15 Amp Plug
	47201	Switch
	41020	Light Tube Holder
	41021	Light Tube Holder Starter
	41022	Light Ballast
	41023	Light Starter

SPARE PARTS (continued)

Machine Section	Part Number	Description
General Frame	12003	Top Frame Assembly
Parts	12004	Bottom Frame Assembly
	12006	Door Assembly
	12007	Corner Post, (4) Required
	12011	Name and Switch Plate
	12012	Front Glass Strip, (2) Required
	12013	Rear Glass Strip, (2) Required
	12016	Motor Mount Plate
	12045	Door Catch, (3) Required
	12051	White Plastic Dome
	12061	Counter Drain Pan Assembly
	12062	"Sharp Blades Warning" Decal
	12063	Protective Light Cover
	12066	Drain Pan Assembly
	22020	Ice Pick
	22024	Shipping Carton
	22034	Ice Shaver Drain Hose
	39018	6 Oz. Cup Dispenser with Bracket
	1088	6 Ounce Snow Dipper
	39068	Ice Scoop
	47010	"Safe Operating Instructions" Label
	47132	Vinyl Glass Channel (14.7 Ft. Required)
	47155	Rubber Foot, 3/4 Inch High, (4) Required
	74119	Warning, Disconnect Power Label
	75220	Hose Clamp with Screw
	76097	Unplug to Clean Label
	76135	Power Cord Tag
	76026	Cord Clip

Glass Replacement Front Glass (1/8" x 15" x 17-7/8")
Side Glass (1/8" x 11-7/8" x 15")

Note: We do not sell replacement glass. Please contact your local hardware store for double strength window glass.

ELECTRICAL SCHEMATIC

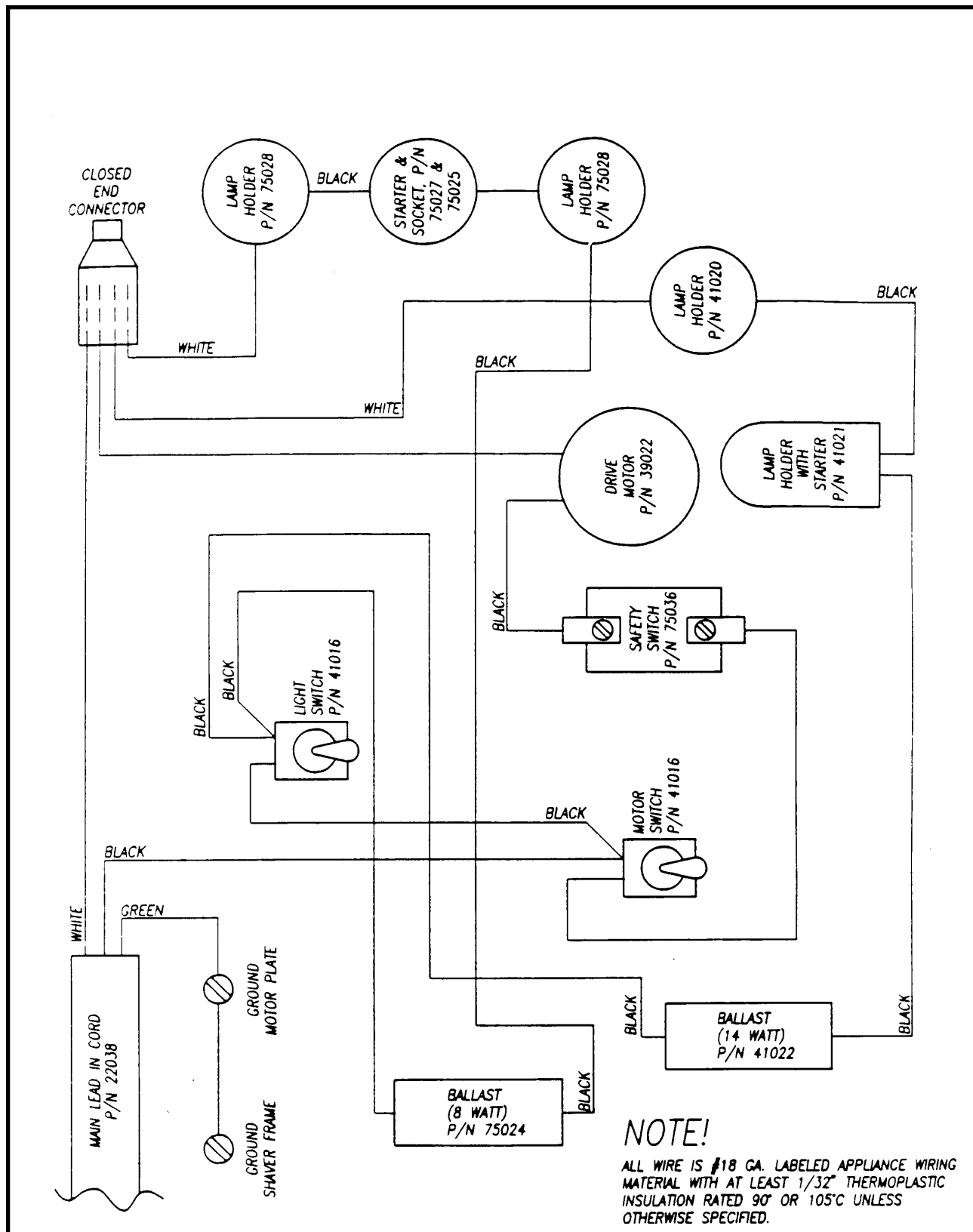

WARRANTY

WE WARRANT to the original purchaser the Gold Medal equipment sold by us to be free from defects in material or workmanship under normal use and service. Our obligation under this warranty shall be limited to the repair or replacement of any defective part for a period of six (6) months from the date of sale to the Original Purchaser with regard to labor and two (2) years with regard to parts and does not cover damage to the equipment caused by accident, alteration, improper use, voltage, abuse, or failure to follow instructions.

THIS WARRANTY IS IN LIEU OF ALL OTHER WARRANTIES EXPRESSED OR IMPLIED, AND OF ALL OTHER OBLIGATIONS OR LIABILITIES ON OUR PART, INCLUDING THE IMPLIED WARRANTY OF MERCHANTABILITY. THERE ARE NO WARRANTIES WHICH EXTEND BEYOND THE DESCRIPTION ON THE FACE HEREOF. We neither assume, nor authorize any other person to assume for us, any other obligation or liability in connection with the sale of said GOLD MEDAL equipment or any part thereof.

The term "Original Purchaser" as used in this warranty shall be deemed to mean that person, firm, association, or corporation who was billed by the GOLD MEDAL PRODUCTS COMPANY, or their authorized distributor for the equipment.

THIS WARRANTY HAS NO EFFECT AND IS VOID UNLESS THE ORIGINAL PURCHASER FIRST CALLS GOLD MEDAL PRODUCTS COMPANY AT 1-800-428-2676 TO DISCUSS WITH OUR SERVICE REPRESENTATIVE THE EQUIPMENT PROBLEM, AND, IF NECESSARY, FOR INSTRUCTIONS CONCERNING THE REPAIR OR REPLACEMENT OF PARTS.

NOTE: This equipment is manufactured and sold for commercial use only.



GOLD MEDAL PRODUCTS COMPANY
10700 Medallion Drive
Cincinnati, OH 45241-4807 USA