

Operation and Installation Manual

RCM-10[®] Remote Control Monitor

and

RSM-10[®] Remote Status Monitor

for the CNA-100[®] & CNA-200[®] Automations

Revision 1.1 9/98

WARRANTY INFORMATION

The RCM-10[®] Remote Control Monitor and the RSM-10[®] Remote Status Monitor, sold by STRONG INTERNATIONAL, are warranted against defects in materials and workmanship for one year from the date of purchase. There are no other express or implied warranties and no warranty of merchantability or fitness for a particular purpose.

During the warranty period, STRONG INTERNATIONAL will repair or, at its option, replace components that prove to be defective, provided the unit is shipped prepaid to the manufacturer directly or via an authorized distributor. Not covered by this warranty are defects caused by modification, misuse or accidents and any further damage caused by inadequate packing for service return.

STRONG INTERNATIONAL's obligation is restricted to the repair or replacement of defective parts and under no circumstances will STRONG INTERNATIONAL be liable for any other damage, either direct or consequential.

Information in this document is subject to change without notice. No part of this document may be reproduced or transmitted in any form or by any means, electronic or mechanical, for any purpose, without the express written permission of STRONG INTERNATIONAL.

© 1997, 1998 STRONG INTERNATIONAL. All rights reserved.

Overview

The RCM-10[®] Remote Control Monitor and the RSM-10[®] Remote Status Monitor are each a ten-station monitor designed specifically for the theater industry. These computer-controlled remote monitors are designed to be compatible with the STRONG CNA-100[®] and CNA-200[®] Automation System. These units allow each projection booth in a cinema multiplex to be monitored from a central location.

This manual provides the installer and user with the necessary information to install, set up and operate the RCM-10[®] and the RSM-10[®] remote monitors. The installer is encouraged to read all sections of the manual before proceeding with the installation. If while installing or operating the RCM-10[®] or the RSM-10[®] monitor you find any part of manual to be unclear or incorrect please let us know. Call STRONG INTERNATIONAL at 402-453-4444 if help or additional information is required.

Product Description

The RCM-10[®] and RSM-10[®] are microcomputer-controlled remote monitors designed to display the status of all the projection booths in a cinema multiplex. The monitors are wired to the CNA automation systems Local Synchronous Network (LSN) and can be located in various places throughout the building such as the projection booth, managers' office and candy counter to provide the personnel with a real time account of each movie house.

The RCM-10[®] and the RSM-10[®] monitors feature four LEDs for displaying the status of each projection booth. Indicated are 'ready to run', projector running, timed or clock start mode, fault and intermission. Each unit is equipped with a sonic alarm and an alarm cancel switch. The RCM-10 monitor is different in that it features start and stop capability for each station.

The remote monitors are connected to the CNA automations via the 2-wire synchronous data bus in a *daisy-chain* configuration. This eliminates the laborious wiring required by the conventional remote stations often needing hundreds of wires and terminations.

Control Panel

The front panel layout incorporates ten separate control/status stations. Each contains four LEDs to display show status. The RCM-10[®] has start and stop capability for each station. An alarm is provided to indicate a fault condition and an alarm cancel switch to silence the alarm at the remote station.

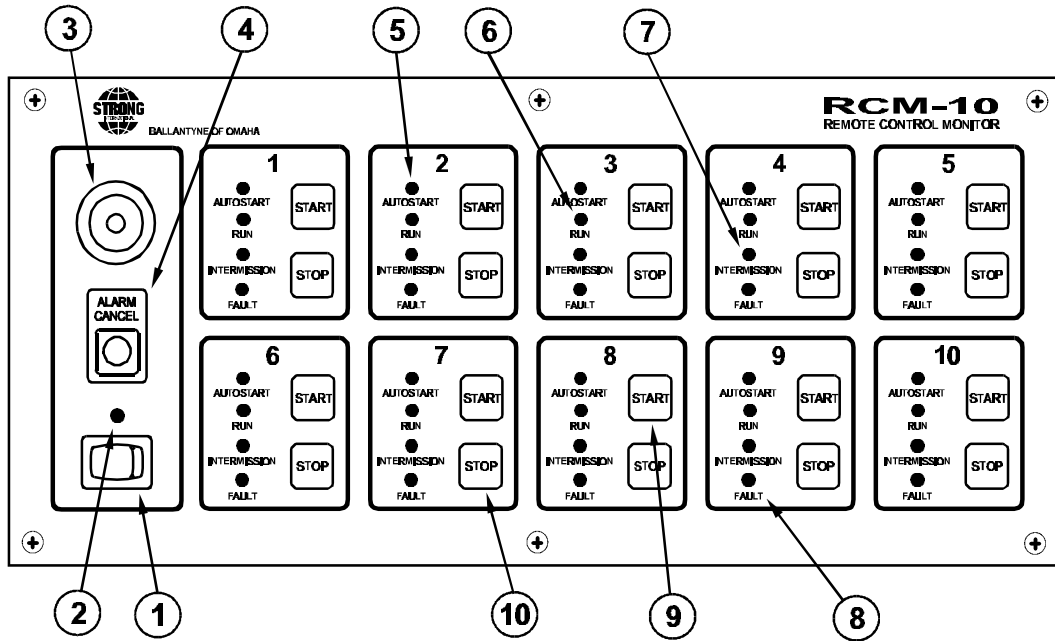

figure A: RCM-10 Control Panel

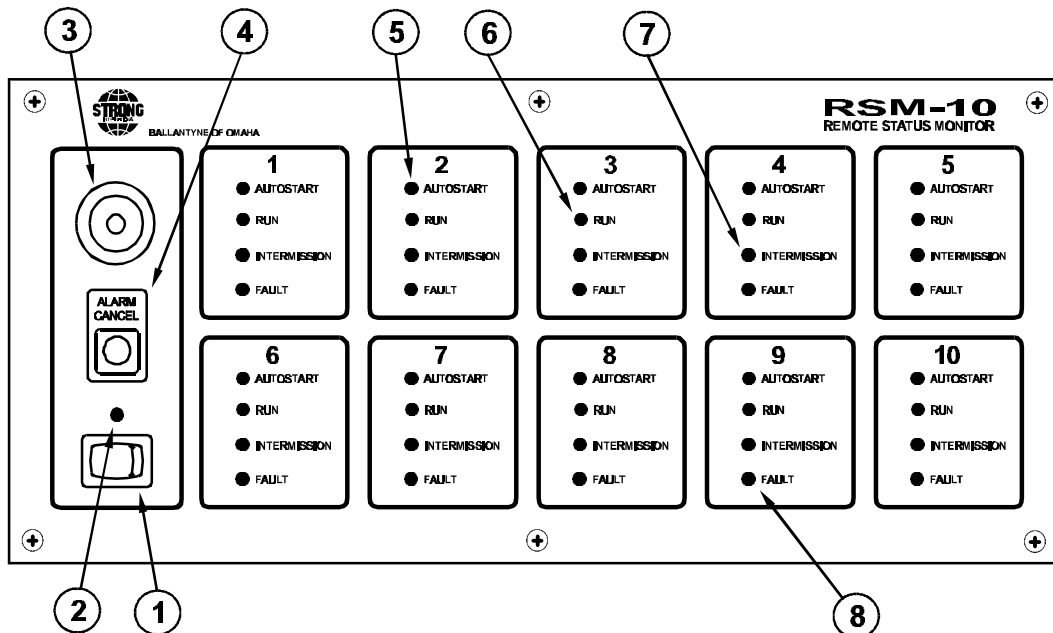

figure B: RSM-10 Control Panel

1) Power Switch

Used to turn on the remote monitor.

2) Power LED

The red power LED is on when power (120 vac/60Hz or 240 vac/50Hz) is applied to the unit.

3) Alarm

The Alarm is sounded to indicate a fault at a CNA-100 or CNA-200. The Alarm is sounded at all remote monitors on the Sync Loop. The alarm can be cancelled at any one of the remotes (on the Sync Loop) or at the CNA that initiated the alarm. The alarm loudness can be set for one of three intensities; LOW(87 dBA), MEDIUM (94 dBA) or HIGH (98 dBA) or can be disabled if desired. See *Configuring the System* section on page 8.

4) Alarm Cancel

This switch is used to silence the alarm in the event of a fault. The Alarm Cancel switch will silence the remote monitor alarm and *all* other remote monitor alarms on the Sync Loop. Alarm Cancel will also cancel the alarm at the CNA Automation.

The ALARM CANCEL switch can also be used for a self-test. Press this switch for seven (7) seconds to enter the self-test mode. The remote monitor will begin to cycle through the LEDs lighting one at a time starting with station number 1. This testing will continue until the switch is pushed again or a five (5) minute timer expires. Operation of the START and STOP switches on the RCM-10 can be also be verified while in the self-test mode. Pressing the START switch will force the AUTOSTART and RUN LEDs on. Pressing the STOP switch will force the INTERMISSION and FAULT LEDs to light.

5) Autostart LED (yellow)

on show is *ready to run* and is in *timed* or *clock start* mode.

off show is *in progress* or in *manual start* mode.

6) Run LED (green)

on projector motor is running.

blinking show is *ready to run* or *ready to resume*.

off show is stopped.

7) Intermission LED (yellow)

on between shows.

blinking show is stopped not due to a fault. (This includes a programmed

intermission.)
 off projector motor is running or show is stopped due to a fault.

8) **Fault LED (red)**

on show is stopped due to a fault and alarm has been cancelled or show is not running and failsafe does not detect the presence of film.
 blinking show is stopped due to a fault and alarm is sounding.
 off fault does not exist.

9) **Start switch**

Press this switch to start or resume a show. (RCM-10 only)

10) **Stop switch**

Press this switch to stop a show or cancel a *timed* or *clock start* operation. (RCM -10 only)

The table below summarizes the eight status conditions displayed by the remote station.

| | READY TO RUN IN AUTOSTART MODE | READY TO RUN IN MANUAL START MODE | SHOW RUNNING | READY TO RUN DURING A PROGRAMMED INTERMISSION | READY TO RESUME | BETWEEN SHOWS & FAILSAFE FAULT | SHOW STOPPED DUE TO A FAULT & ALARM IS SOUNDING | SHOW STOPPED DUE TO A FAULT & ALARM HAS BEEN CANCELLED |
|--------------|--------------------------------|-----------------------------------|--------------|---|-----------------|--------------------------------|---|--|
| AUTOSTART | ON | OFF | OFF | OFF | OFF | OFF | OFF | OFF |
| RUN | BLINK | BLINK | ON | BLINK | BLINK | OFF | OFF | OFF |
| INTERMISSION | ON | ON | OFF | BLINK | OFF | ON | OFF | OFF |
| FAULT | OFF | OFF | OFF | OFF | OFF | ON | BLINK | ON |

Installation

The equipment should be carefully inspected for signs of visible damage resulting from transportation and handling. Please notify the freight carrier immediately if damage is found. First, verify that the power supply inside the unit is set to the same voltage (120 or 240) that is powering the unit. If it is not, move the jumpers labeled W1 and W2 to the appropriate locations.

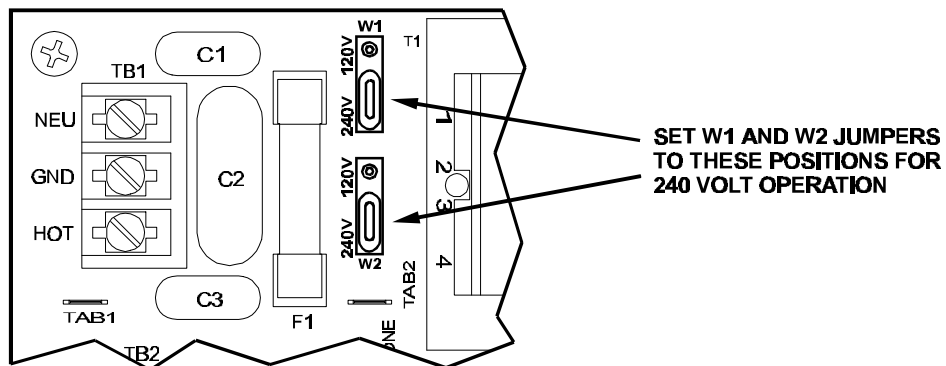
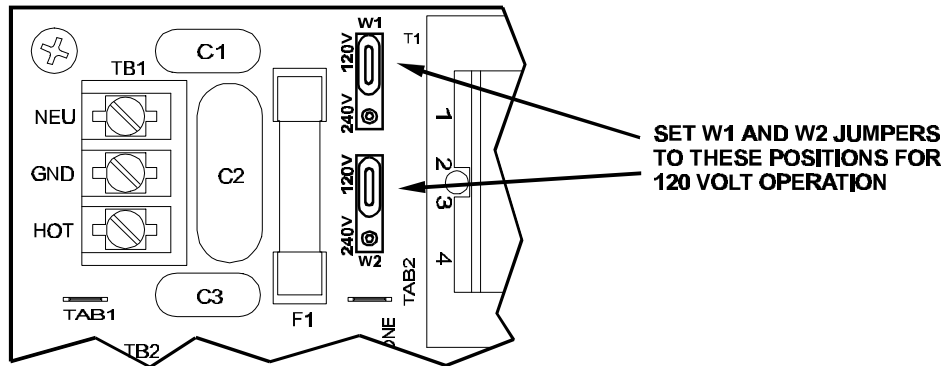

figure C: Power supply voltage selection

Mounting the Remote Monitor

The monitor is housed in a steel cabinet which is dimensioned in *figure D*. The four (4) mounting holes are keyholes capable of accepting #10-24 screws with a maximum head diameter of 3/8 inches. The cabinet is designed to be surface or flush mounted, 1/8 inch diameter holes in each ends of cabinet are provided for wall stud mounting. Next, prepare the cabinet for mounting by removing the desired knockouts. Several 7/8 inch knockouts are provided in the cabinet for external wiring of power and communications. Note: optional hardware is available for rack mounting the monitor.

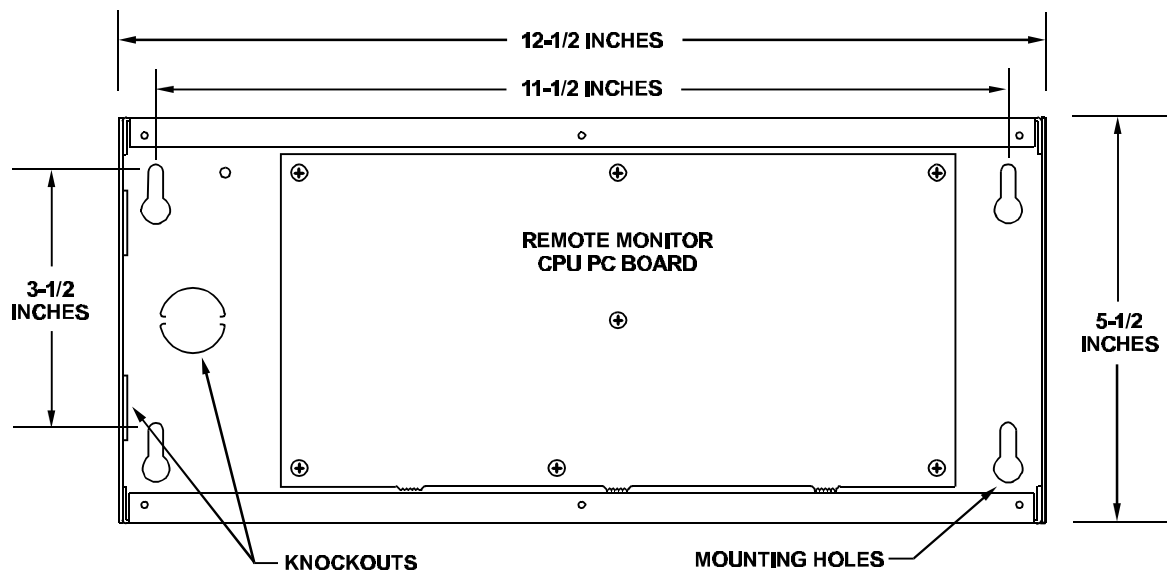

figure D: Remote Monitor cabinet

Wiring the Remote Monitor

Remember that during installation insure that all requirements of the National Electric Code and local codes are satisfied. For remote units installed in the projection booth, be sure to run *clean* power (dedicated to the Remote Monitors and CNA systems only) to all Remote Monitors and CNA automation systems from the service entrance panel or closest branch panel. The line, neutral and ground wires should all run back to the main service panel (separate from all other loads). It is acceptable and preferred if all remotes and automations were run from a single distribution point.

IMPORTANT NOTE: Do not connect the projector motors, changeovers, xenon rectifiers or other heavy or noisy loads to this circuit.

TB1 is the AC power input termination. This terminal block is located in the upper right corner of the pc board. The monitor will operate on 120 or 240 vac. **MAKE CERTAIN** the jumpers on the power supply are set to the correct voltage before applying power. See *figure E*.

Communication wiring between the CNA automations and Remote Monitors is accomplished using 2-conductor, twisted pair with a shield. Wire gage is dependent on the length of the wire needed. In general, 22 gage is sufficient. Many cable manufacturers offer a broad range of 120-ohm cables designed for RS-485 applications. We recommend **Belden 9841** or equivalent. Also be certain *polarity* is observed. See *figure E*.

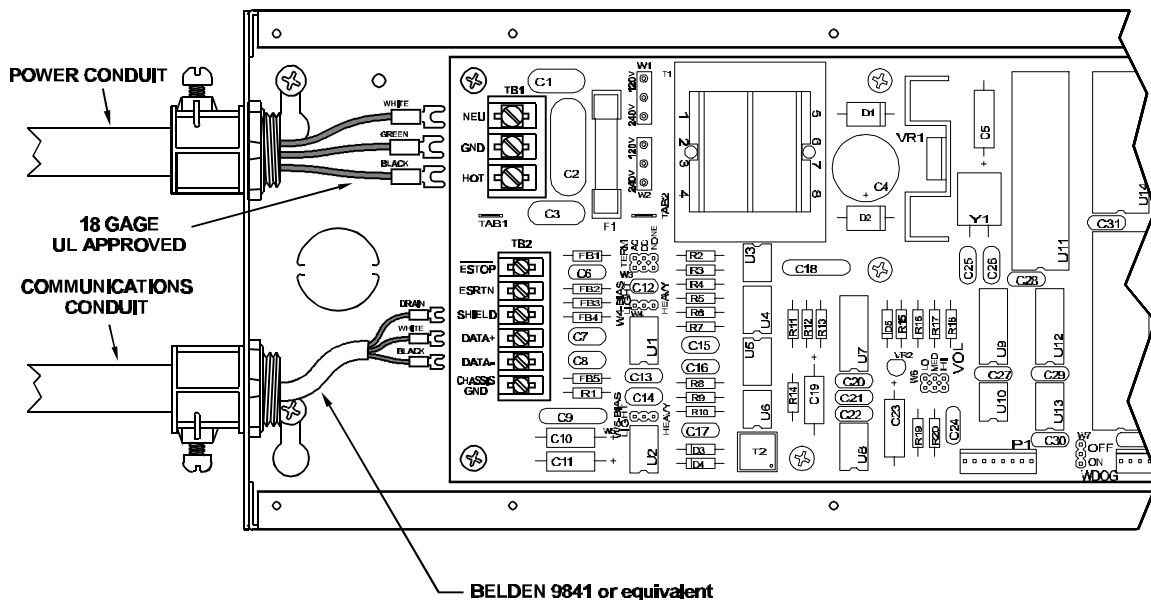

figure E: Power and Communications termination

When planning the communication wiring, keep the cable away from equipment that generates electrical noise, such as power conduits, fluorescent lighting fixtures, air conditioners, etc. Choose cable routing paths in such a way to prevent damage to the cable.

The required method for communication wiring of the Remote Monitor/CNA automation system is the *daisy-chain* configuration, a system in which the transmission line continues from one unit to the next. See figure F for the *daisy-chain* connection topology. Do not branch or spoke devices.

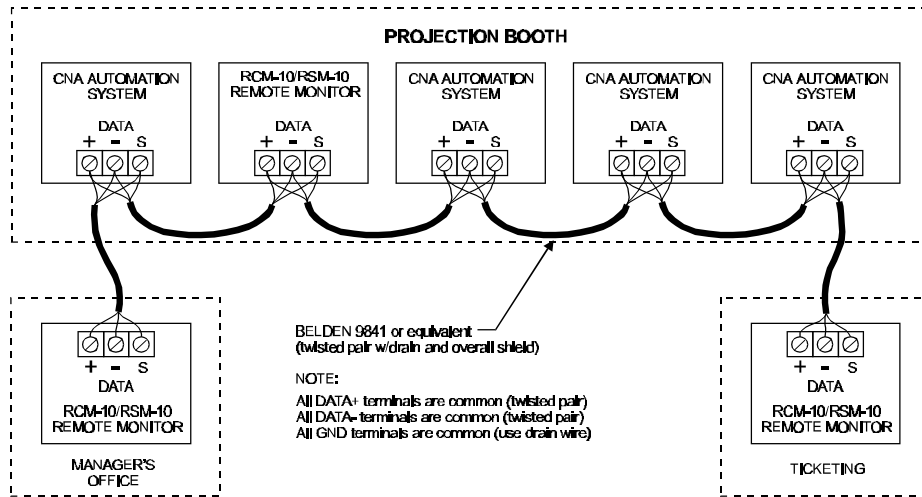

figure F: *Daisy-chain* connection

Emergency Stop Input

Each Remote Monitor features a master *Emergency Stop* input. This is designed to be wired to the Fire Alarm System. Shorting the two inputs labeled ESTOP and ESRTN (TB2-1 and TB2-2) at any Remote Monitor will force a stop condition to all CNA systems on the network. The connection should be made to a normally open *dry* relay contact as shown in *figure G*.

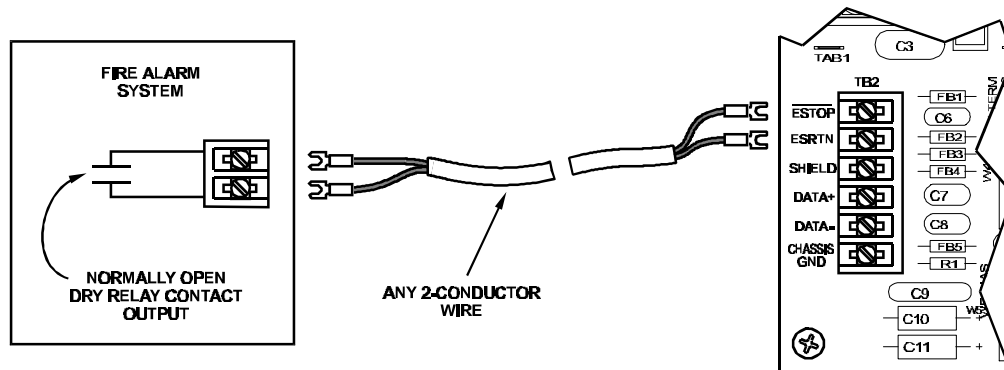

figure G: Emergency Stop wiring

Configuring the System

The synchronous communications *network* can support up to 64 devices (Remote Monitors, CNA-100S, CNA-200s and a Host). **Remote Monitors and CNAs will each require a unique ID number.** ID 0 will be used by the *Host PC*, IDs 32 to 63 are assigned to Remote Monitors as necessary and IDs 1 to 63 are assigned to CNAs as necessary. Normally the CNA's ID numbers will be assigned starting at 1. The Remote Monitor's IDs should be assigned to the higher numbers starting at 63 and working down. Note that as many Remote Monitors can be assigned to a sync loop number as desired (switches and LEDs all will work in parallel). *Figure H* below demonstrates the Sync Loops and IDs within a network.

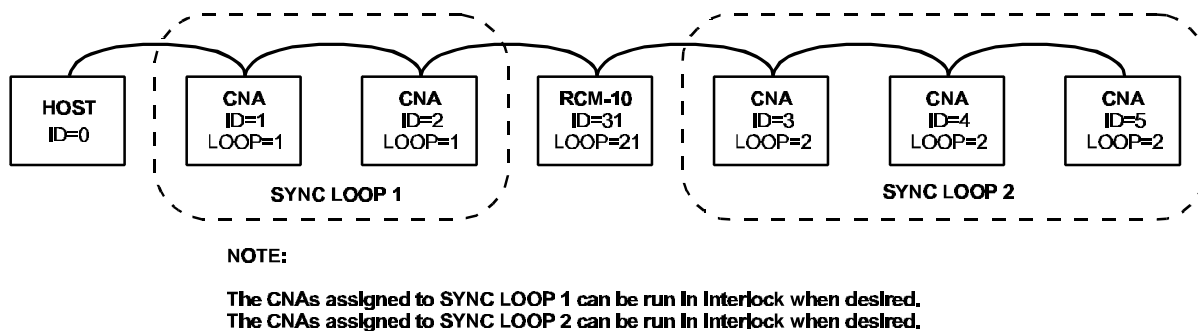

figure H: Sync Loop and ID numbers in a network

Within the Sync network, a maximum of 20 *sync loops* can be defined. The CNA uses sync loops to run projection systems in *interlock*. The legal range of CNA sync loop numbers are 1 through 20. For large multiplexes that want to monitor more than ten CNAs on the network, up to six Remote Monitors can be **grouped** together to monitor up to fifty-seven (57) houses with one group of three Remote Monitors. Remember, the maximum number of devices that can be connected to the Sync network at one time is 64 and one is the *Host PC*. For very large multiplexes it may be practical to divide the network into two smaller networks. Call the factory for suggestions on planning the wiring in a large multiplex.

Sync loop numbers 21 through 26 are predefined and used for Remote Monitors.

Remote Monitor setup

First locate the eight position DIP switch designated SW1. See figure I.

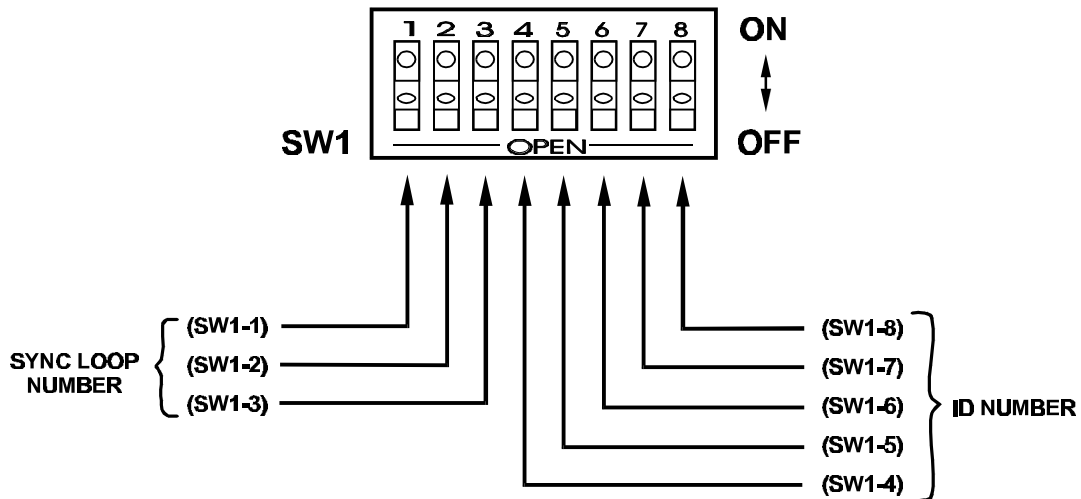

figure I: DIP switch

To configure the Remote Monitors for Loop number the DIP switches SW1-1 through SW1-3 must be set as follows:

| Remote Monitor CNA's at ID | Sync Loop Number | Remote Monitor DIP switch setting | | |
|----------------------------|------------------|-----------------------------------|-------|-------|
| | | SW1-1 | SW1-2 | SW1-3 |
| 1 to 10 | 21 | OFF | OFF | OFF |
| 11 to 20 | 22 | OFF | OFF | ON |
| 21 to 30 | 23 | OFF | ON | OFF |
| 31 to 40 | 24 | OFF | ON | ON |
| 41 to 50 | 25 | ON | OFF | OFF |
| 51 to 60 | 26 | ON | OFF | ON |

To configure the Remote Monitors for ID number the DIP switches SW-4 through SW-8 must be set as follows:

| Sync ID Number | Remote Monitor DIP switch setting | | | | |
|----------------|-----------------------------------|-------|-------|-------|-------|
| | SW1-4 | SW1-5 | SW1-6 | SW1-7 | SW1-8 |
| 63 | ON | ON | ON | ON | ON |
| 62 | ON | ON | ON | ON | OFF |
| 61 | ON | ON | ON | OFF | ON |
| 60 | ON | ON | ON | OFF | OFF |
| 59 | ON | ON | OFF | ON | ON |
| 58 | ON | ON | OFF | ON | OFF |
| 57 | ON | ON | OFF | OFF | ON |
| 56 | ON | ON | OFF | OFF | OFF |
| 55 | ON | OFF | ON | ON | ON |
| 54 | ON | OFF | ON | ON | OFF |
| 53 | ON | OFF | ON | OFF | ON |
| 52 | ON | OFF | ON | OFF | OFF |
| 51 | ON | OFF | OFF | ON | ON |
| 50 | ON | OFF | OFF | ON | OFF |
| 49 | ON | OFF | OFF | OFF | ON |
| 48 | ON | OFF | OFF | OFF | OFF |
| 47 | OFF | ON | ON | ON | ON |
| 46 | OFF | ON | ON | ON | OFF |
| 45 | OFF | ON | ON | OFF | ON |
| 44 | OFF | ON | ON | OFF | OFF |
| 43 | OFF | ON | OFF | ON | ON |
| 42 | OFF | ON | OFF | ON | OFF |
| 41 | OFF | ON | OFF | OFF | ON |
| 40 | OFF | ON | OFF | OFF | OFF |
| 39 | OFF | OFF | ON | ON | ON |
| 38 | OFF | OFF | ON | ON | OFF |
| 37 | OFF | OFF | ON | OFF | ON |
| 36 | OFF | OFF | ON | OFF | OFF |
| 35 | OFF | OFF | OFF | ON | ON |
| 34 | OFF | OFF | OFF | ON | OFF |
| 33 | OFF | OFF | OFF | OFF | ON |
| 32 | OFF | OFF | OFF | OFF | OFF |

Alarm loudness setting

The alarm loudness can be set for one of three intensities; LOW(87 dBA), MEDIUM (94 dBA) or HIGH (98 dBA) or can be disabled if desired. See *figure J* below.

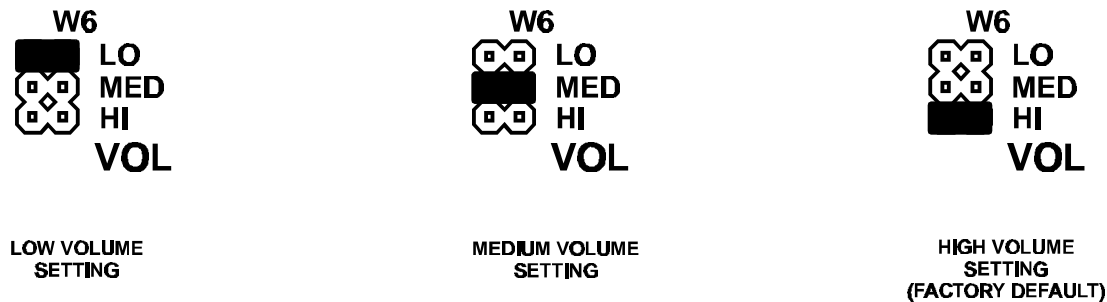

figure J: Alarm setting

Final checkout and operation

When the electrical installation is completed and the all CNA-200s and Remote Monitors are correctly configured, power up all devices on the network. Follow the steps outlined below to verify proper operation.

1. Check the Local Sync Network Status screen on each CNA-200 to determine that all CNA-200s and Remote Monitor IDs are displayed.
2. Check each Remote Monitor. The power LED should be lit. At least one of the LEDs should be lit on each active station. If the film is not loaded at the CNA-200 the INTERMISSION LED should be on. Refer to the *Control Panel* section on page 3 and 4 for a description of the status LEDs.
3. Take each CNA-200 through a *dummy* run and verify the status LEDs on all Remote Monitors.
4. If using the RCM-10[®] Remote Control Monitor, verify that the START and STOP switches are working at each station.

Troubleshooting with the Remote Monitor

The red LED labeled LED 1 on the mainboard is a communications status indicator. The LED will either be blinking at a *fast rate* (on 3 times per second), a *slow rate* (on 1 time per second) or *off*. This status LED can provide much information and will aid in troubleshooting the Remote Monitor and the network.

The following table shows the three modes of LED status and the conditions that may exist. This table assumes you have attempted to wire the network.

| |
|--|
| <p>(1) Fast Blinking Rate - Monitor OK. Communications OK.</p> |
| <p>1. The Remote Monitor is working and is communicating properly with CNA-200(s).</p> |
| <p>(2) Slow Blinking Rate - Monitor OK, but not communicating with CNA-200(s).</p> |
| <p>1. Data (+) and Data (-) are open. 2. Data (+) and Data (-) are shorted together. 3. CNA-200s connected to the network are not powered up. 4. The ID number is set the same somewhere else on the network.</p> |
| <p>(3) Off - Monitor maybe OK. Communications not OK.</p> |
| <p>1. Only Data (+) is open. 2. Only Data (-) is open. 3. Data (+) is shorted to shield. 4. Data (-) is shorted to shield. 5. Data (-), Data (+) or shield are cross wired. 6. ID number is set to zero (0). 7. The Remote Monitor is not working.</p> |

If there are no LEDs lit on the front panel (except for the power LED), the possible causes are:

1. The Sync Loop number is not set correctly.
2. CNA-200s connected to the network are not on.
3. Data (+) and/or Data (-) are open.
4. Data (+) and Data (-) are shorted together.
5. Data (+) and/or Data (-) are shorted to shield.
6. Data (-), Data (+) or shield are cross wired.
7. The Remote Monitor is not working.
8. ID number is set to zero (0).

System Specifications

General:

Power requirements 8.5 watts (maximum)

Power Supply Voltage 90-130 VAC or 180-260 VAC
(user selectable) 50-60 Hz single phase

Input Power Fuse 1/2 amps 3AG normal blow
(LITTLEFUSE #312.500 or equivalent)

Dimensions width . . . 12-1/2 in. (31.8 cm)
height . . . 5-1/2 in. (13.9 cm)
depth . . . 3 in. (7.6 cm)

Weight 4.6 lbs (2.1 kg)

Communication:

RS485

Half duplex

Protocol: SCIBEK (Bit-oriented protocol developed by *TL Industries* for the theatre industry)

Troubleshooting

PROBLEM: A Remote Monitor is missing from the status overview display on all CPA-10s.

CHECKS: Is the power LED *on* at the Remote Monitor?

Are any other LEDs on the front panel working?

Remove the control panel and check the DIP switch configuration at the Remote Monitor to be sure **sync ID** and **sync loop** numbers are correct (Refer to *Configuring the System* section on pages 7 and 8).

Be sure the STATUS LED on the pc board is blinking.

If the Remote Monitor is at the end of a transmission line are the "DATA +" and "DATA -" wires reversed or not connected?